

SYSTEMATIZATION OF THE WATER SUPPLY SYSTEM OF ZARAGOZA

SWITCH PROJECT

SWITCH is a project that boosts the efficient use and management of water by citizens. It forms part of the Sixth Framework Programme of the European Union and is headed by UNESCO-IHE (Institute for Water Education)

This project aims at the development, application and showcasing of solutions contributing to obtain urban water sustainable and efficient projects for the “city of the future”.

Measurement sectors (DMAs) in Actur area -forming part of the demonstration project for the management of water demand in the city of Zaragoza- have been planned and implemented.

Different “good practices” that will be presented later on, have been obtained from the experience learned from these first four sectors which are being used for drawing-up a survey on the systematization of the water supply system of Zaragoza.

INTRODUCTION

A correct management of the water distribution system of the city is essential for reaching the general goal of reducing the volume of drinking water consumed and a more efficient.

The Service of Exploitation of Systems and Cartography of the City of Zaragoza is in charge of drawing up the strategic plan for the system as well as its management and monitorization.

One of the basic points of a water management system is to measure flow volumes and users’s consumption. These data allow experts to evaluate the functionality of the system and plan strategies for improving the distribution system.

The plan and exploitation of the water supply systems affects directly the wise an rational use of water, and also implies –apart from the rationalization of consumption policies for users- control policies and the reduction of leaks in collection and transport infrastructures.

Another starting point is the rationalization of the existing infrastructures; a planning and systematization of actions for renovation and construction of new infrastructures to provide the city with a functional and sustainable basic infrastructure.

The initial basic parameters are the provision of a service with enough supply, quality of water and technical and economic efficiency within the framework of the sustainability of the system.

Performance -considered as the quotient between the volume controlled and the volume supplied- is a basic parameter to define the efficiency of a system.

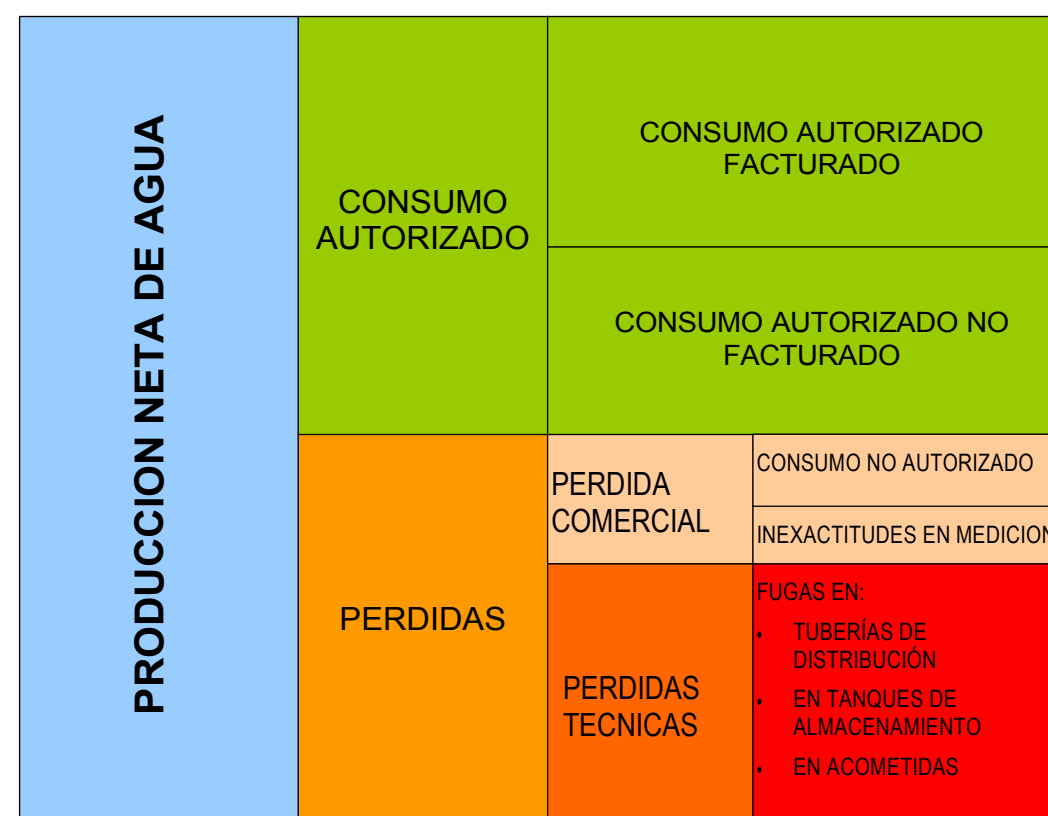

BALANCE HIDRICO PROPUESTO POR LA IWA

First of all, from a working point of view, a good management system implies the improvement of performance through action in two possible fronts; on the one hand a reduction of leaks, and, on the other, a reduction of demand.

The reduction of leaks –included in the category named commercial losses- implies a reduction of non-authorized or non-accounted consumption, and the minimization of measurement inaccuracies through action plans.

A big part of real leakage comes from the so-called technical waste, provoked by the characteristics of the system and complementary systems (tanks, pumping, etc.).

The sectorization of the system allows us a detailed monitorization of the system, and also the possibility of controlling pressure to reduce leaks.

Taking into account visibility and effects, leaks can be divided in two types:

1. Roturas explosivas, generally with a violent origin (breakings in fragile pipes), and with evident effects on the pavement, urban furniture, nearby dwellings, etc.

These kind of leaks are easy to detect and must be immediately repaired, since they can provoke the interruption of the service in more or less big areas.

2. Slow leaks -generally of small volumes of water- which do not provoke an immediate interruption on the supply system and are only visible after a long time (collapse, humidity, etc). Its early detection is difficult and laborious. Depending on the system's condition, the total volume of leak provoked by this kind of problem can be very considerable. Its minimization is important for increasing the performance of the system.

In order o detect leaks, is necessary to act in a systematic way by a preventive procedure of prospection and identification.

The sectorization and monitoring of the service is fundamental to reduce economic and time costs derived from this kind of leaks. The identification of anomalies in the flow curves of the volumes of flow and pressure of every sector help us to identify problems and fence in action areas for a more exhaustive search for the causes of the problem detected. The statistical treatment of the data collected help also to evaluate the service performance in an objective way.

PRESSURE MANAGEMENT

One of the service standards of the system is to guarantee a minimum pressure in every point of the system during the whole day.

The quantity of water distributed by the system change every day, with demand peaks in the morning and in the evening, followed by periods of low consumption at night and certain hours in the morning. Taking into account that the system has been planned to guarantee a minimum pressure during the whole day, this quantity is only reached during short periods of time, coinciding with demand peaks. As a result of these criteria, the distribution system is subjected to an excessive pressure during most of the day.

The Working Group on Water Leakage of the International Water Association (IWA) has developed during the last years a proposal for a strategy for managing water leaks in distribution systems.

The minimum threshold for the leaks is considered to be the minimum of leaks produced in a system under optimal running and maintenance conditions. As a system deteriorates, leaks will increase if they are not restricted by these four characteristics (repair in less time, active search for leaks, infrastructure management, and pressure management).

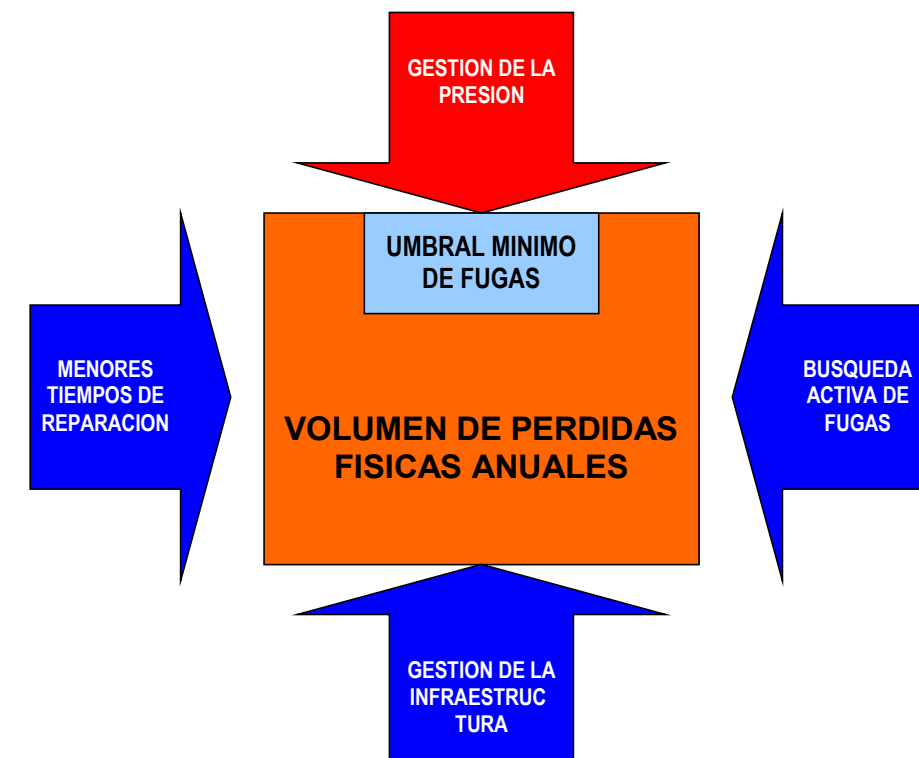

Estrategia IWA para la reducción de las pérdidas de agua

The direct relation between pressure and leak flows has been proved. The Working Group on Leaks of the IWA and the U K Water Industry Research Programme recommend the use of a simple exponential operation for representing the relation between leak flows and pressure.

$$Q_f = P^{N1}$$

$$Q_{f1} / Q_{fo} = (P_1 / P_0)^{N1}$$

where:

- Qf1 is the reverse flow after pressure reduction.
- Q10 is the reverse flow before pressure reduction.
- P1 is pressure after the implementation of reduction
- P0 is pressure before the implementation of reduction

N1 changes depending on the characteristics of the pipe. (0.5-2).

A pressure control valve (actually being adjusted), has been installed in sector S-04 to evaluate proceeding for decreasing the number of leaks. This valve only limits pressure at night to 30 mWC, and will collect data with that operating curve.

ZARAGOZA SUPPLY SYSTEM

PRESSURE STEPS

Due to the different topographical levels of Zaragoza, water distribution is made by steps with different pressure, adapting land to the geographical areas and keeping an operating pressure level in the whole city. Therefore, several tanks and pumping facilities are necessary.

The areas with different pressure are these:

- Casablanca: includes the biggest part of the city, Old Town, City Centre, Almozara, Las Fuentes, the Left Bank, part of Delicias, Logroño Road, Castellón Road, Malpica, etc.
- Valdespartera: with the districts of Casablanca, Valdefierro, Oliver, Mirablueno, rest of Delicias, Universidad, Romareda, arriving to Plaza de Paraíso.
- Canteras gravity: includes the area between river Huerva, Canal Imperial and Goya and Tenor Fleta avenues.
- Canteras pumping: districts of Torrero and la Paz.

- Los Leones-Academia: area around Huesca Motorway: military zone, San Gregorio, San Juan, Juslibol and Camino de los Molinos.
- Garrapinillos, Alfocea, Montañana, Peñaflor and Villamayor have independent areas. Villarrapa has an autonomous supply system.
- Valdespartera Ecocity.

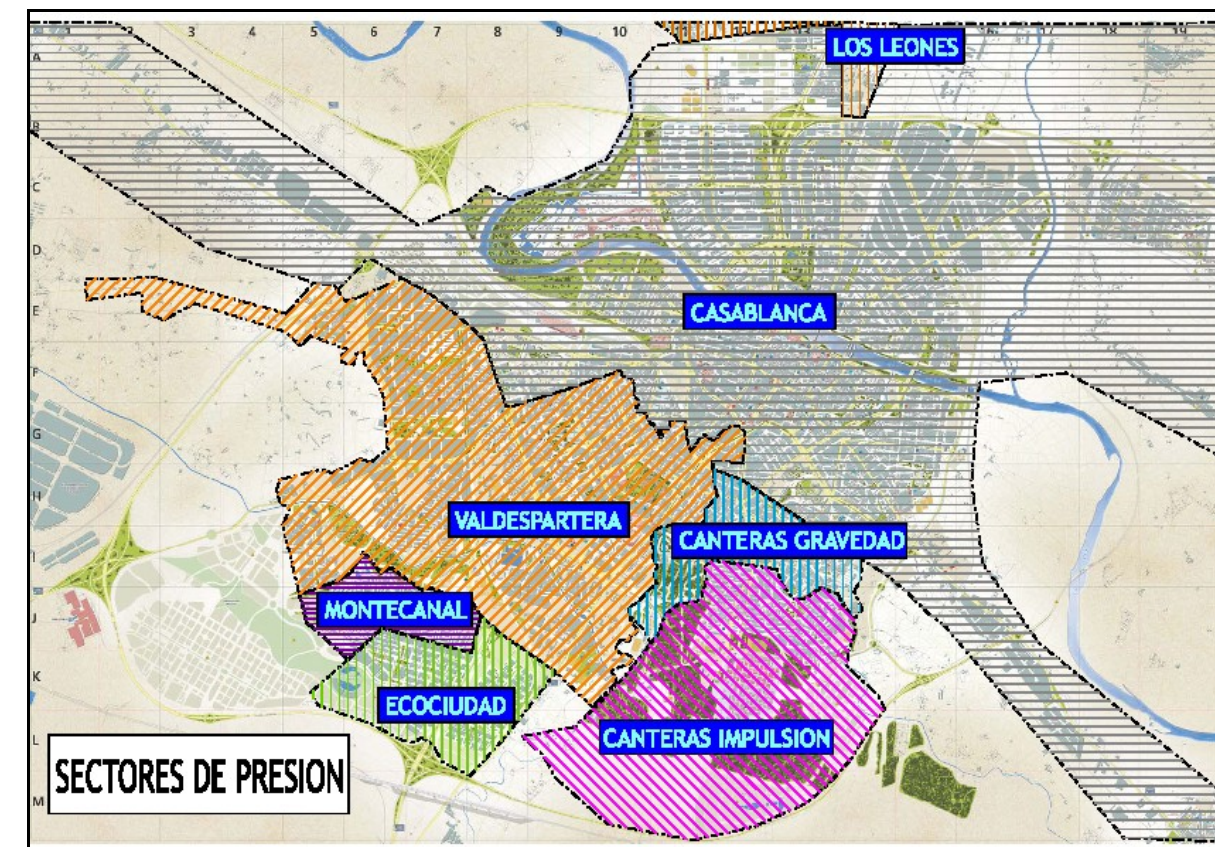

It can be said that Zaragoza has an average distribution pressure, between 20 and 45 m. of water column. The top is around 80 m. in precise areas.

Diameters are big enough –the most used is 150 mm. Therefore, flow speed is slow and residence time is sometimes excessive. On the other hand, this makes possible a bigger flexibility for an alternative supply during cuts of the main thoroughfares of the city.

ESQUEMA DE IMPULSIONES Y DEPOSITOS

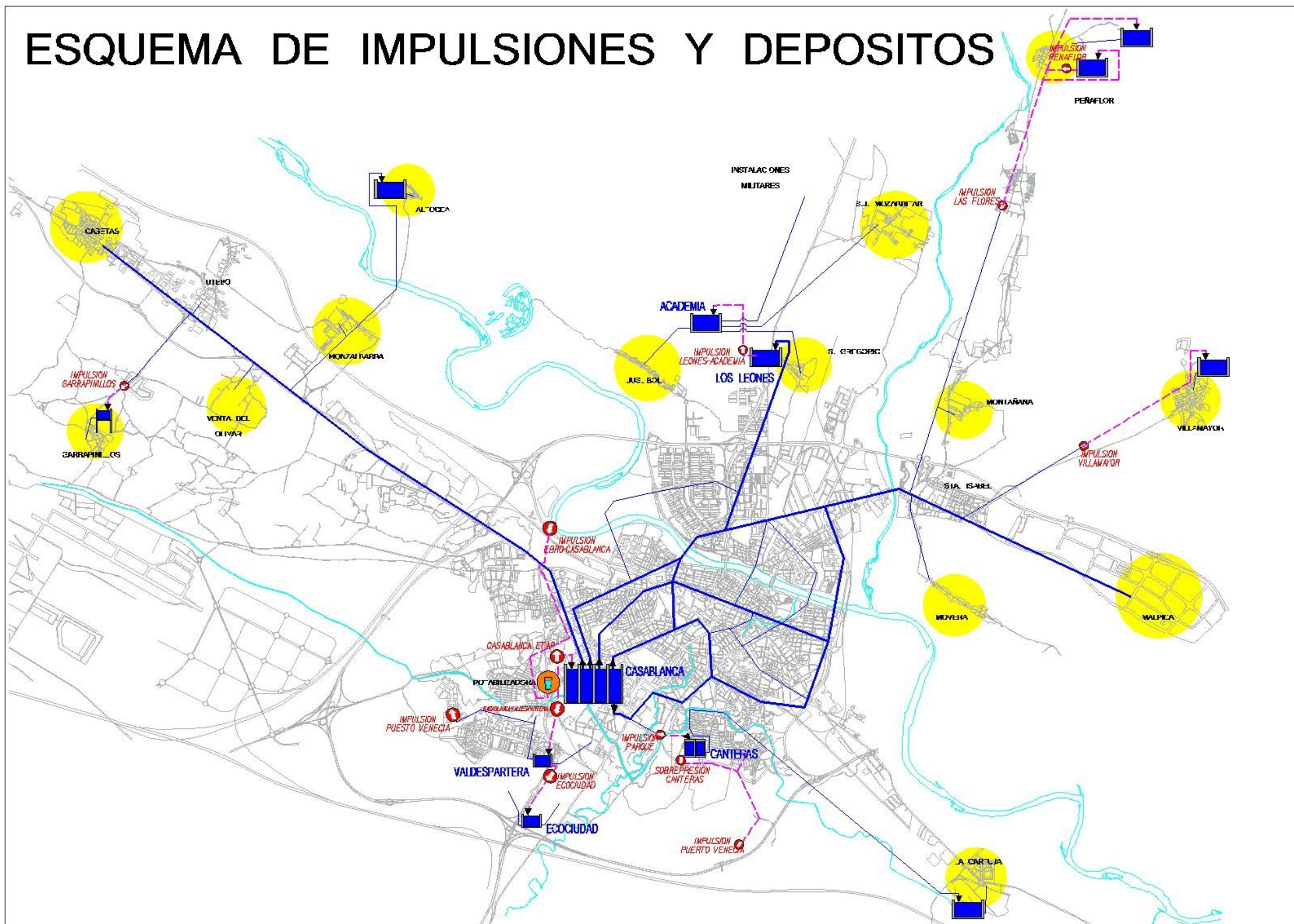

STRUCTURE OF THE MAIN BRANCHES OF THE SYSTEM

The water distribution system of the city of Zaragoza -after water has been purified- start at Casablanca tanks, from which water is directly distributed through pumping to other tanks or flowing directly to the pipe system.

Due to the distribution layout of the areas served, the system includes several zones relatively independent, with different distribution of the pressure steps.

These are the supply areas with its tanks and pumping:

AREA	TYPE	VOLUME	HEIGHT water sheet	COMMENTS
Casablanca	CASABLANCA TANK	180,000 m3	241 m.	Includes the biggest part of the city: Old Town, City Centre, Almozara, Las Fuentes, Left Bank, part of Delicias, Logroño Road, Castellón Road, Malpica, etc.
Valdespartera	VALDESPARTE RA TANK	42,000 m3	270 m.	Includes the districts of Casablanca, Valdefierro, Oliver, Miralbueno, rest of Delicias, Universidad, Romareda to Plaza de Paraíso
Ecociudad	ECOCIUDAD TANK	11,100 m3	313.5 m.	Pumping from Casablanca tanks
Canteras gravity	CANTERAS TANK	14,400 m3	256 m.	Includes the area between the river Huerva, Canal Imperial and the avenues of Goya and Tenor Fleta.
Canteras pumping	PUMPING			Includes Torrero and la Paz districts
Los Leones	LOS LEONES TANK	4,000 m3	227 m.	Includes the area around Huesca Motorway: military zone, San Gregorio, San Juan, Juslibol, and Camino de los Molinos. The water flowing to Los Leones tanks is pumped to the Academia Tank
Academia	LA ACADEMIA TANK	15,000 m3	282 m.	
Peñaflor	TANK	200 m3	288 m.	
Garrapinillos	TANK	100 m3	221 m.	
Villarrapa	TANK	560 m3	221 m.	
	PUMPING			Montañana, Puerto Venecia, Empresarium, Rosales del Canal

Supply for these areas is generally made by big diameter pipes (above 500 mm.), from which water is distributed through a net-shape system with pipes of a smaller diameter.

The approximate distribution of pipes by diameter and material within the municipal supply water system of Zaragoza in the year 2010 is this:

Materials used for the pipes of Zaragoza supply system (2010)	
Material	Longitud en m.
Sheet	724
Fibre cement	304.418
Ductile iron	740.375
Grey cast iron	25.890
Reinforced concrete	71.928
Unknown material	1.687
Polyethylene	33.312
Plastic	2.314
PVC	55.782
TOTAL	1.236.429

Diameter of pipes of Zaragoza supply system (2010)	
Diameter in mm:	Longitud en m.
<=100	180.111
100<Ø<=150	535.465
150<Ø<=300	314.966
300Ø<=1500	205.888
TOTAL	1.236.430

GRANDES ARTERIAS

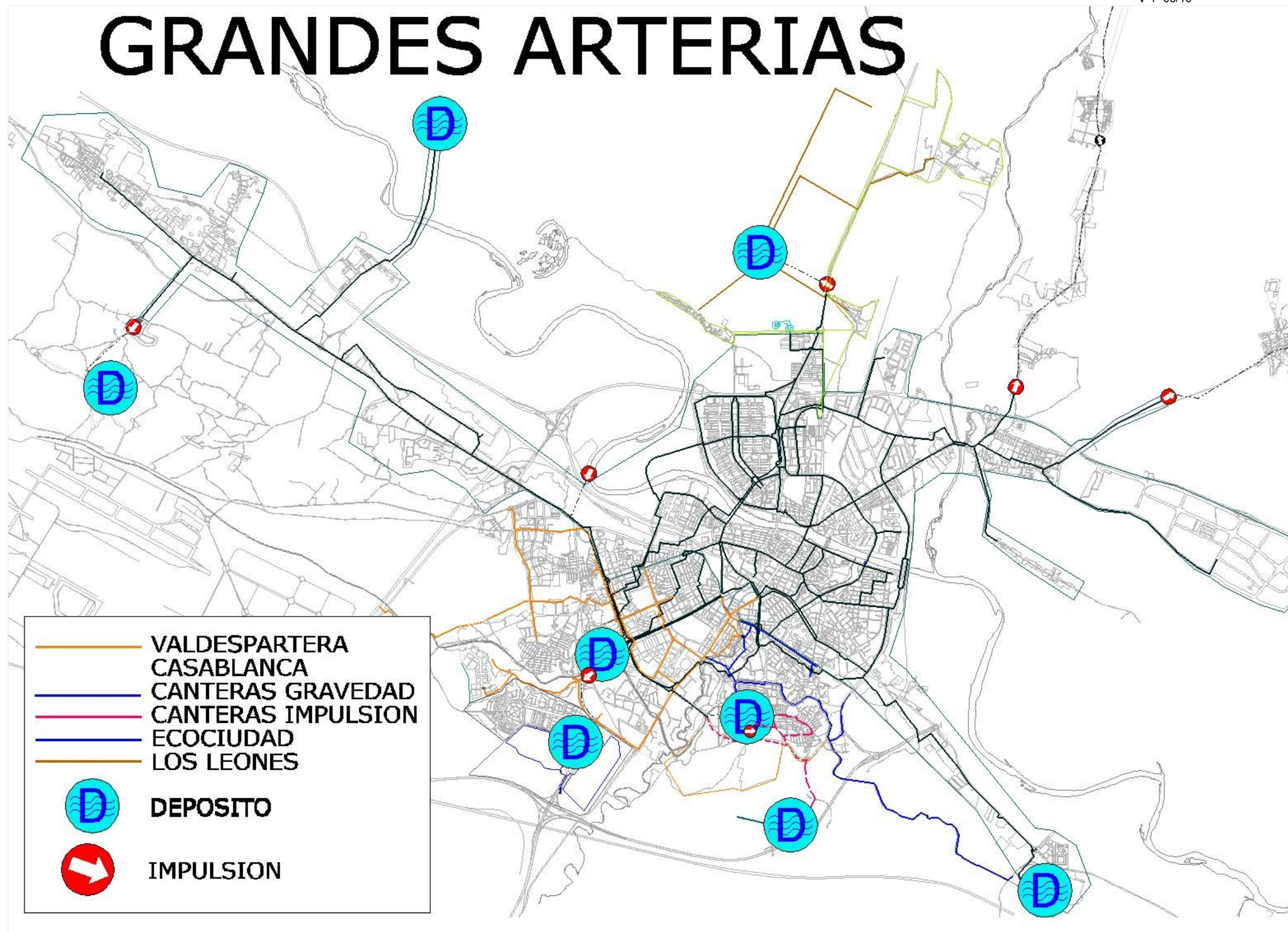

BASIC GUIDELINES FOR PLANNING

From a technical point of view, a short, medium or long term system planning needs to specify several guidelines for local precise actions (renovations, new systems, repairs, etc), for achieving some precise goals, giving priority to the use of the resources for coordinated actions that can contribute to reach those goals in the most efficient way.

GOALS

The system should reach –among others- the following goals:

- **Guarantee the functionality of the system** to provide the city with the adequate water supply system.
- **Optimize water saving**, minimizing uncounted leaks and consumption, and increasing control on the system.
- **Decrease the costs derived from the implementation and exploitation** of the system by means of continuing with the renovation of obsolete systems, simplifying them, and reducing non-operational duplicities of stretches with big pipes, cut points, connections, valves, etc, as well as improving and keeping the functionality and flexibility of the system.

GUIDELINES

Plan the structure of the large diameter network in a flexible and efficient way, keeping supply by alternative circuits in case of breaking or cut, and, in any case, reducing the time and effects of service breaks (splits, exploitation and/or renovation of the system, etc.)

The development of these action lines applied to the water supply system will make possible the availability of a framework strategy for all those actions that could affect the system (projects for renovating services, new projects, repairs, etc).

GUIDELINE 1

Plan the large diameter network and its connections, suppressing or simplifying the knots and stretches of old systems that, due to their placing, traffic, etc, can be difficult to renovate and repair.

The system of big pipelines (from now on large diameter network), must be planned starting from these premises;

- Present structure, state and functionality of the system.
- Foresee new urban developments and needs.
- Adaptation to sectorization of the small diameter network.
- The present operational capacity of the stretches of the system must be researched into, and those built with damaged or obsolete materials, and with frequent problems and malfunctioning must be identified.
- A medium and long term plan must foresee a flexible large diameter network with alternative systems to feed the different pressure steps for renovations, breakings or supply cuts, minimizing the duration of the interruption and its degree of importance.

GUIDELINE 2

Research into the simplification of the connection knots of big stretches with a limited operational capacity from a general vision of the system, will be a start base for eventual projects affecting those areas.

The system of big supply pipelines must be simplified, guaranteeing its functionality and flexibility.

It will be taken into account the simplification of big connection knots between large diameter network, adapting them to the structure of the areas supplied by different tanks and/or pumpings, and removing incompatible connections between pressure steps.

Research into a re-arranging of the connection knots of big stretches with a limited operating capacity from a general vision of the system, will make possible the availability of a starting point for possible projects affecting those areas.

Taking into account that the progressive adoption of sectorization of the small diameter network will make possible a reduction of the present connections of the large diameter network with the small diameter network, the limitation of those connections will be researched into, removing those incompatible or inoperative (for example connection of big pipes with small diameter systems, incompatible with the sectorization and/or the pressure steps).

Particularly, the disposition of the connection knots and layouts of the large pipelines must be researched into in those points in which, due to its placing, road traffic, transport systems, renovation and repairing is specially difficult.

GUIDELINE 3

Deep into the sectorization of the system, creating the necessary control points to know costs and identify areas with an inadequate relation between total consumption/counted consumption. This will provide the information needed for an efficient control, renovation and repair of the whole system.

The extension of sectorization will also make possible the limitation of the existing connections between the big stretches and the distribution system small diameter network, as specified in the paragraph on Guideline 2.

The analysis and plan of the sectorization of the distribution system small diameter network deals also with in another document named "Systematization and Modernization of the Supply System of Zaragoza – small diameter network -" made by this Department.

GUIDELINE 4

Determine and delimit the separation of the large diameter network (big stretches) and the distribution system (local systems), simplifying the choice of diameters and layouts in projects for local distribution systems.

The big pipelines for supplying different sectors present special characteristics on the diameter, population, problems provoked by the service cutting, and special elements (valves, small boxes, etc). These pipes must not have many connections to local systems since, in theory, they can be trouble points.

The characteristics, requirements and functionality of big distribution pipes and the local water distribution system are different. A comprehensive division of the system into sectors implies a need of a certain division of the water supply system in two sub-systems (large and small diameter network):

This document proposes to determine and define the division of the big pipes and the distribution system (local systems), simplifying the election of diameters, connections and plans for future systems.

GUIDELINE 5

Define and balance the limits of areas with a minimum pressure step (served by the same tank or pumping system).

These areas (known as pressure steps) present, in principle, a certain incompatibility of interconnection, since every one of them depends on the height of the tank and the characteristics of pumping. An uncontrolled connection between any of them will produce dysfunctions and a possible collapse of the service (emptying of the tanks, bursts by an excess of pressure, etc).

Therefore, it is necessary to restrict and adjust the possible connection points between the areas, in order to avoid unprogrammed connections among incompatible pressure steps.

The existence of certain controlled connections must be taken into account, which will allow us - in special cases due to the circumstances of the service- to make the connection in a controlled way (through valves for reducing pressure, etc).

It is fundamental to define stable limits between the pressure steps with a shape that will depend -among others- on the altitude of the city, the country, the materials used and the age of the systems, the capacity of the tanks and pumping systems, pressure high, the population served, minimum pressure and quantity of water to supply, etc.

The stability of these boundaries will no be total, since they could change depending on future needs and developments of the system.

It is also important to define an adaptation plan for the present pressure steps, in order to reach the foreseen levels, as well as complementary actions (it is foreseen an on-time renovation of inadequate systems, coordination with new systems, etc).

GUIDELINE 6

Research into the possible alternatives for supply areas with a high number of important problems or limited functionality.

GUIDELINE 7

Specify pipeline stretches with important problems, identify the causes and propose the guidelines to follow.

It is fundamental to specify the stretches that include big diameter network which suffer important and frequent problems, identify the causes and propose guidelines to follow (renovation, alternative circuits, etc).

SECTORIZATION

The implementation of the systematization and rationalization of the system, consists of creating areas adapted to the structure and functionality of the system, supplied from a unique point placed in the red en alta, where flows and pressure is controlled.

This control point -composed of a magnetic flow meter, a pressure sensor and an electronic system for data registration and communication- registers the flows and pressure during the day, and can send stored data in a continuous way (with permanent connection to data) or in a periodic way (through a system of mobile phone via SMS).

A correct management of the data obtained will allow us to get this:

- **Fast detection of problems**, such as leaks and bursts (by a sudden or untimely increase of consumption), that can be transmitted to the teams of leak detection and be repaired before they can produce important damages.
- **Control of leaks by sector**. Comparison of the consumption obtained at the control point of every sector with the whole consumption of the counters placed in every control point
- **Data obtained for** gauging the GIS simulation system.
- **Data** to be used for statistics for an adequate interpretation of the way the system works, allowing us a correct planning and a continuous improvement of its functionality.

The sectorization of the supply system implies the creation of two different types of system, one that we will call "large diameter network", composed of big diameter pipes (over 300 mm.) and which implement the first step for carrying water from the different tanks and pumping systems to the secondary system of local distribution, using, in general, smaller diameters (300 mm or less).

Generally speaking, every sector will be fed from a point of the large diameter network, through a stretch of pipe with enough diameter to guarantee a correct supply to the sector, without an excessive lost of charge; the rest of the water intakes to sectors are kept closed, avoiding stretches of blind pipes and an excessive retention of water in the systems.

Therefore, it is necessary to plan the division of the system into sectors, including a perimeter pipe, that, apart from contributing to distribute flows in the sector, can allow us to eliminate the blind pipes.

In our case, every sector must have a minimum of two connections with the large diameter network, through, at least, a short stretch of 300 mm pipe. The control point will be placed at one of those stretches, and, all of them will have a stop valve to isolate the sector with the large diameter network .

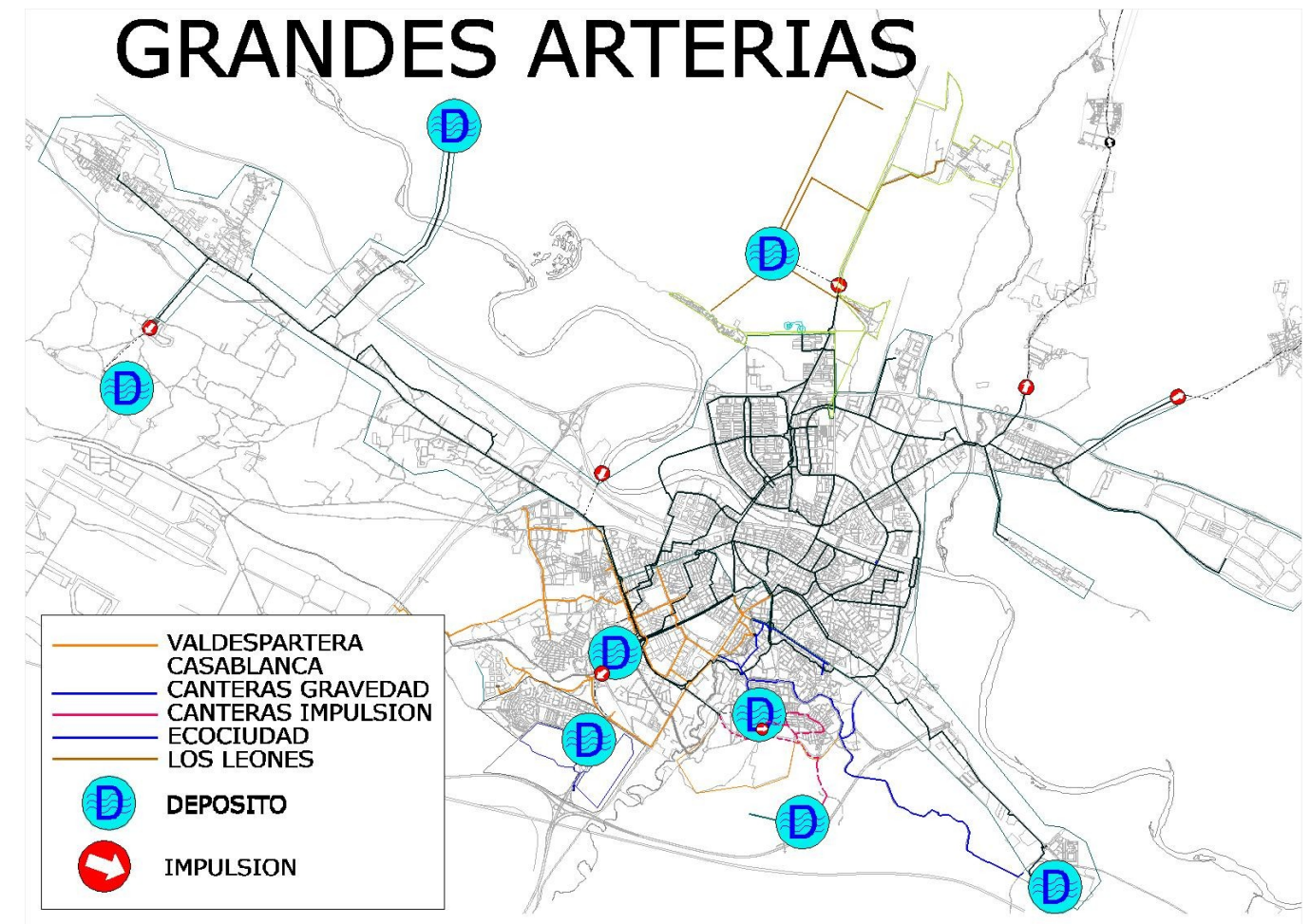

For defining the sectors, the following starting parameters have been taken into account:

- Topology of the distribution system
- Equivalent number of inhabitants: around 12,000
- Calculation of consumption by person and day: => 250 l/person/day
- Peak factor: 2.5 times the average consumption
- Minimum consumption factor: 0.20 times the average consumption
- If it is possible, the sector will include a tube of 300 mm of diameter around its whole outline
- A simulation in every sector will be made to know the **capacity** of the connection for the supplying of the sector.

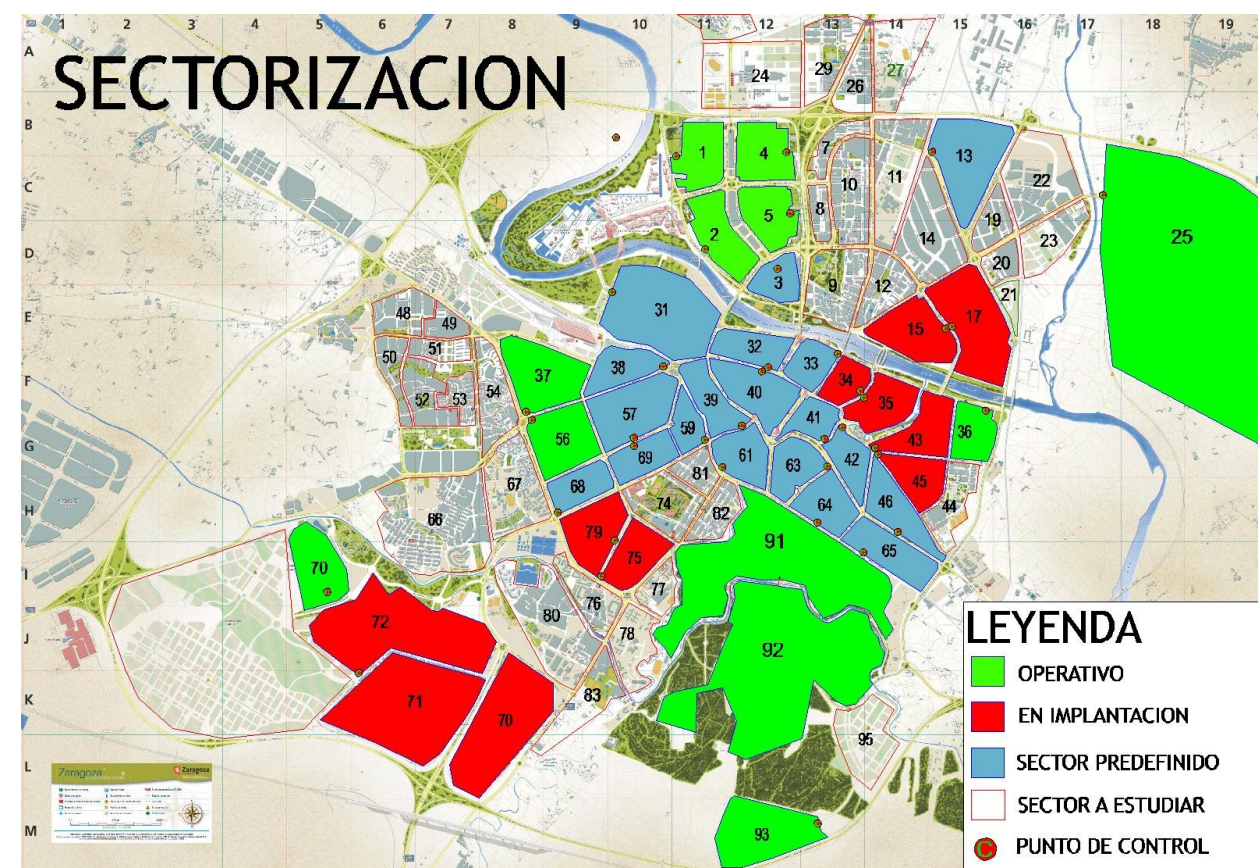

ACTION PROCESS

The first action implemented has been the division in four sectors (named S-01, S-02, S-04 and S-05) placed at the south of the Actur district and at the city north.

The initial action process has been this:

1. - Identification of the areas of the Actur district to be divided into sectors



2. - Survey on the system and plan of every sector
 - Identification of the valves to close
 - Identification of the location of the control point
3. - Definition of the characteristics of the control point
4. - Implementation of the control points
5. - Parametrization of the teams and data collection at the operating center
6. - Tracking of the data received and identification of maintenance problems.
7. - Adaptation, parametrization and correction of working problems in the control points.

8. - Systematization of the problems and methods of correction used, and drawing up of internal recommendations for the implementation of new sectors.

The documents for the strategic planning of the system -actually being drawn- will come from this action process integrated in Switch project, through the application of the experiences obtained until now in sectors, S-01, S-02, S-04 and S-05-. Several more sectors have been incorporated into the system and the implementation of other two is foreseen.

In ideal conditions, the process for the planning and sectorization of a water supply system, should be implemented taking into account several consecutive stages that could be described as it follows:

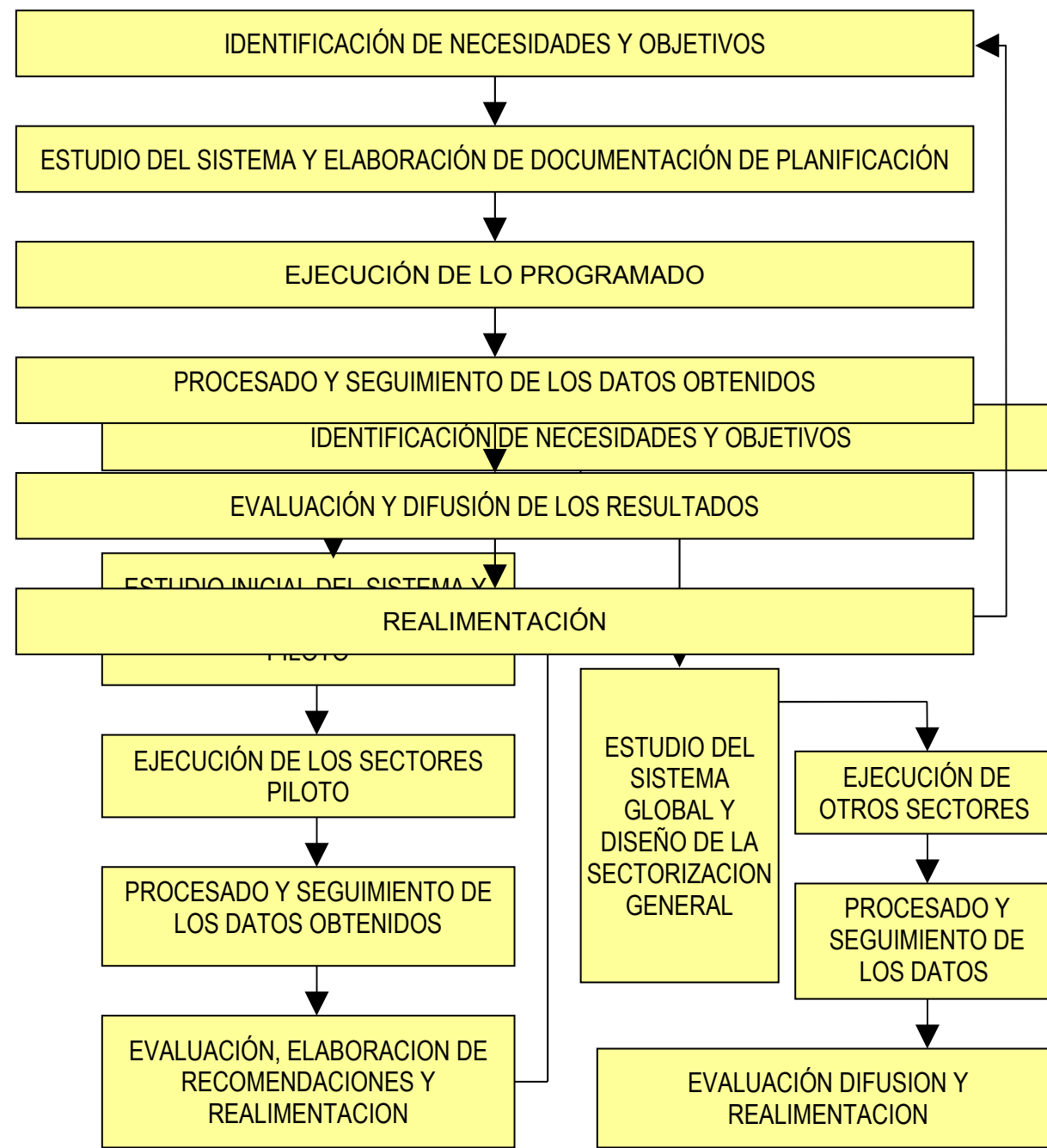

In our case, this scheme must have been adapted to the circumstances and availability of the present moment. Thanks to SWITCH programme, pilot sectors (S-01, S-02, S-04 and S-05) have been introduced in parallel to the elaboration of the global plan for the system. This has allow us to research into the real way the sectors work and into the data obtained from the implementation, running, problems, and feedback for the whole plan.

These are in detail the activities implemented and the results obtained until now.

IDENTIFICATION OF THE REQUIREMENTS AND GOALS

In this stage, which focuses on the identification of requirements and the determination of goals, a particular objective has been drawing-up a control process for the water supply system as tool to reach the general goal of reducing the volume of drinking water consumed, promoting at the same time a more efficient use.

INITIAL RESEARCH INTO THE SYSTEM AND PLAN FOR THE PILOT SECTORS

Taking as starting point the existing topology of the system and the above mentioned initial parameters, several actions such as the layout of sectors, the position of the control point, and the establishment of the valves -in order to guarantee the total closing of the sector's perimeter- have been carried out.

IMPLEMENTATION OF THE PILOT SECTORS

Once defined the parameters for every sector, the control point, the closing for the valves, and the parametrization of the flow meters and the data logger were placed.

The control point for the monitorization of the sectors S-01, S-02, S-04 and S-05 present the following basic characteristics:

SECTOR	PLACE	TYPE	Ø
S-01	Luis Legaz Lacambra Street	Electromagnetic flowmeter ABB MAGXE Datalogger Multilog GSM/SMS	300
S-02	Clara Campoamor Street	Electromagnetic flowmeter ABB MAG Multilog Datalogger GSM/SMS	300
S-04	Adolfo Aznar Street	Electromagnetic flowmete ABB MAGMASTER Pressure valve Datalogger: Pegasus GSM	300
S-05	Pablo Neruda	Siemens electromagnetic MAG 8000	300

	Street		
--	--------	--	--

Dataloggers are parametrized to store every 15 minutes the data related to the average consumption from the last 15 minutes as well as the average pressure, sending those data every 24 hours to the control center through SMS.

PROCESS AND MONITORING OF THE DATA OBTAINED

Once a day, data are received by the control center, storing every 15 minutes pressure and average flow parameters.

Thanks to SCADA programme, it is possible to visualize the data curves as well as the lists of parameters (pressure-volume of flow) used for the corresponding statistical treatment.

A first visual control of the curve shape of the volume of flow and pressure, gives us a basic idea of the possible anomalies of the running of the system (important sudden leaks, explosive leaks, unusual consumption, etc).

The control of the minimum daily consumption (at night) can be an index of the performance of the sector (slow leaks), and gives us a basic indication for improving the system.

A pressure valve has been installed in sector S-04 to regulate pressure down the river from the control point. The valve has just been parametrized to limit pressure at night (in a low consumption period) and evaluate the effects of pressure on leaks. Right now, the pressure stability given by the valve is being assessed but the stage of data processing has not started yet.

ASSESSMENT, DRAWING UP OF ADVICES AND FEEDBACK

In this stage, apart from data collection and a periodic control of curves by the control points, the detection of the running levels of the control points is also carried out. The following important effects have taken place:

- Lack of signal sent in some places, and sometimes, lack of phone coverage (SMS).
- Detection by the flow meters of low water flowing speed during long periods of time (coinciding with periods of low consumption), under the normal working limits of the flow meters, with a resulting lost of precision in measurements.
- Difficult access to the rooms where the electronic devices are placed, for its parametrization a periodical revision, since they are in closed areas that need an adequate security system (protection against fall, road traffic, etc).

Running experience on these four sectors, has allowed experts to elaborate different recommendations to be taken into account for the implementation of new sectors in the system. These recommendations will be mentioned further on.

PILOT SECT

SECTOR 01

The main characteristic

- This sector has a use.
- It contains approxin
- The average const flow measured from
- The minimum daily coherent data)
- The diameter of the
- - The average spee

COMMENTS

The following charact 11/05/10, once eraser precise errors in the se we can notice the follo

1. A very low speed in meter.
2. The estimated cons
3. Two different perio first one of dispers variation of the high period of adjustme picking signal. In a during the monitori in the second perio average of 3.85 l/s
4. From the graphics effects that must be

Zaragoza AREA DE INFRAESTRUCTURAS Y PARTICIPACION CIUDADANA
SERVICIO DE EXPLOTACION DE REDES Y CARTOGRAFIA Sección de Cartografía y Explotación de Redes

FECHA: 01/06/10
SECTOR: 1
AREA (Ha): 42,12
CONSUMO MEDIO l/s: 13,78
*(1 semana, lunes-domingo)

DATOS DE SIMULACION

PRESIONES EN PUNTO DE ALIMENTACIÓN m.c.a.

P. Mínima	N/D
P. Media	N/D
P. Máxima	N/D

ACCIONES PARA LA SECTORIZACION

CODIGO	ACCION	PRIORIDAD A = alta M = media B = baja	Fecha de ejecución
1			
1			
1			
1			
1			
1			
1			
1			
1			
1			
1			

CAUDALIMETRO

MODELO: ABB MAG XE Ø300
UBICACIÓN: NC/Legaz Lacambra
FECHA DE PUESTA EN MARCHA: EN FUNCIONAMIENTO
TELEFONO:

NOTAS

HORA	ALTURA PIEZOMETRICA	PRESION (m.c.a.)
0,00		
1,00		
2,00		
3,00		
4,00		
5,00		
6,00		
7,00		
8,00		
9,00		
10,00		
11,00		
12,00		
13,00		
14,00		
15,00		
16,00		
17,00		
18,00		
19,00		
20,00		
21,00		
22,00		
23,00		

SECTOR DE PRESIÓN

ANTES	CASABLANCA
DESPUES	CASABLANCA

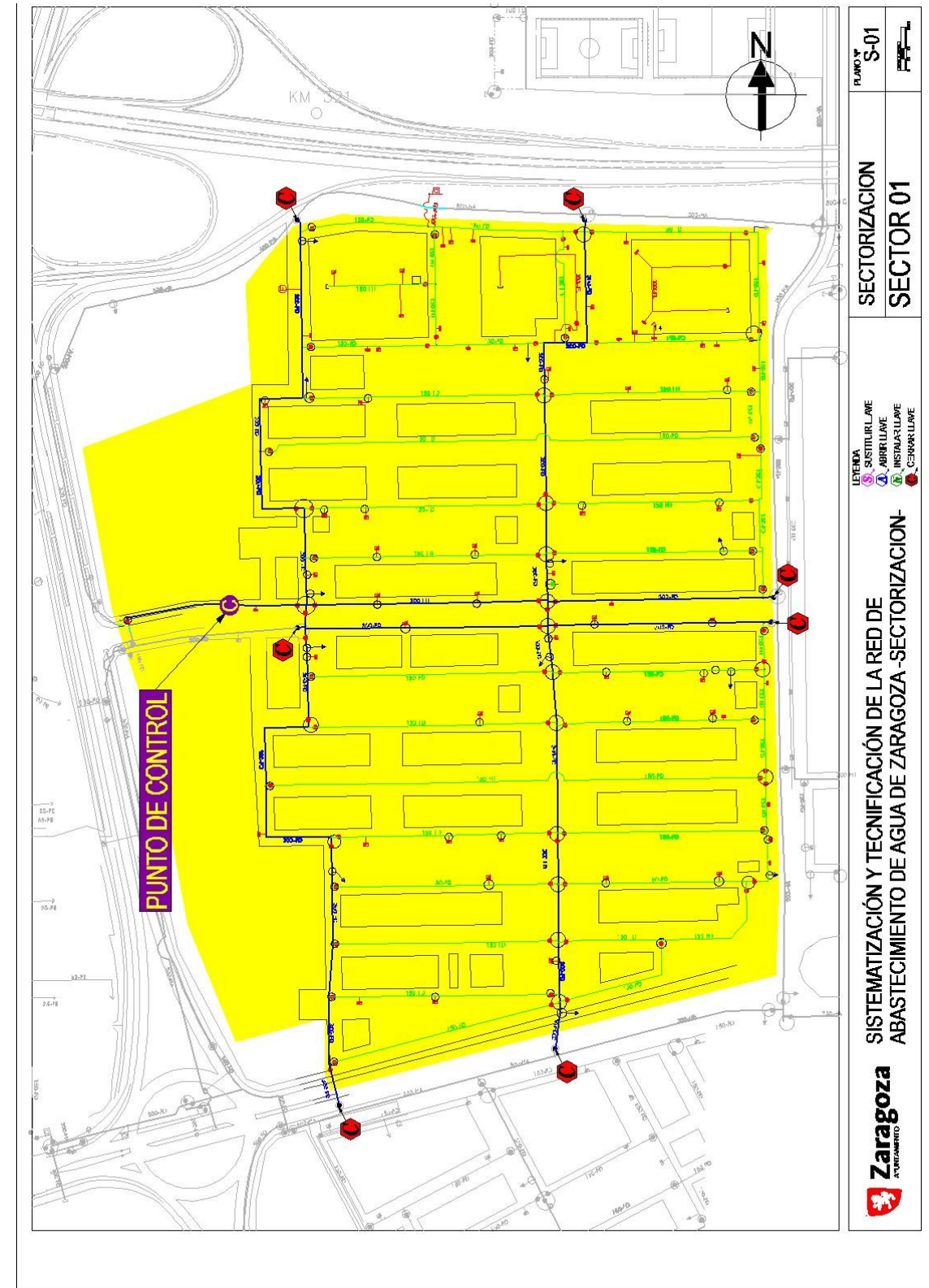
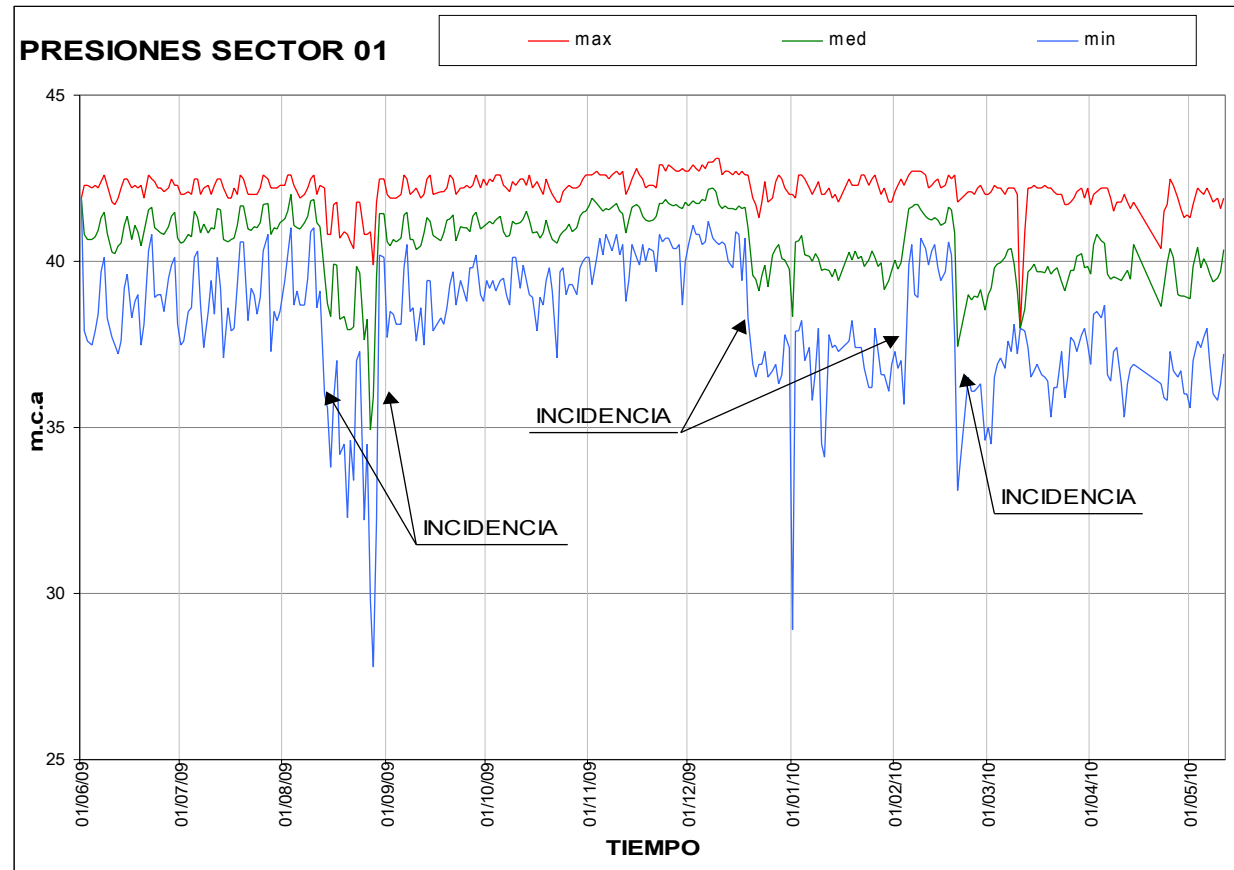
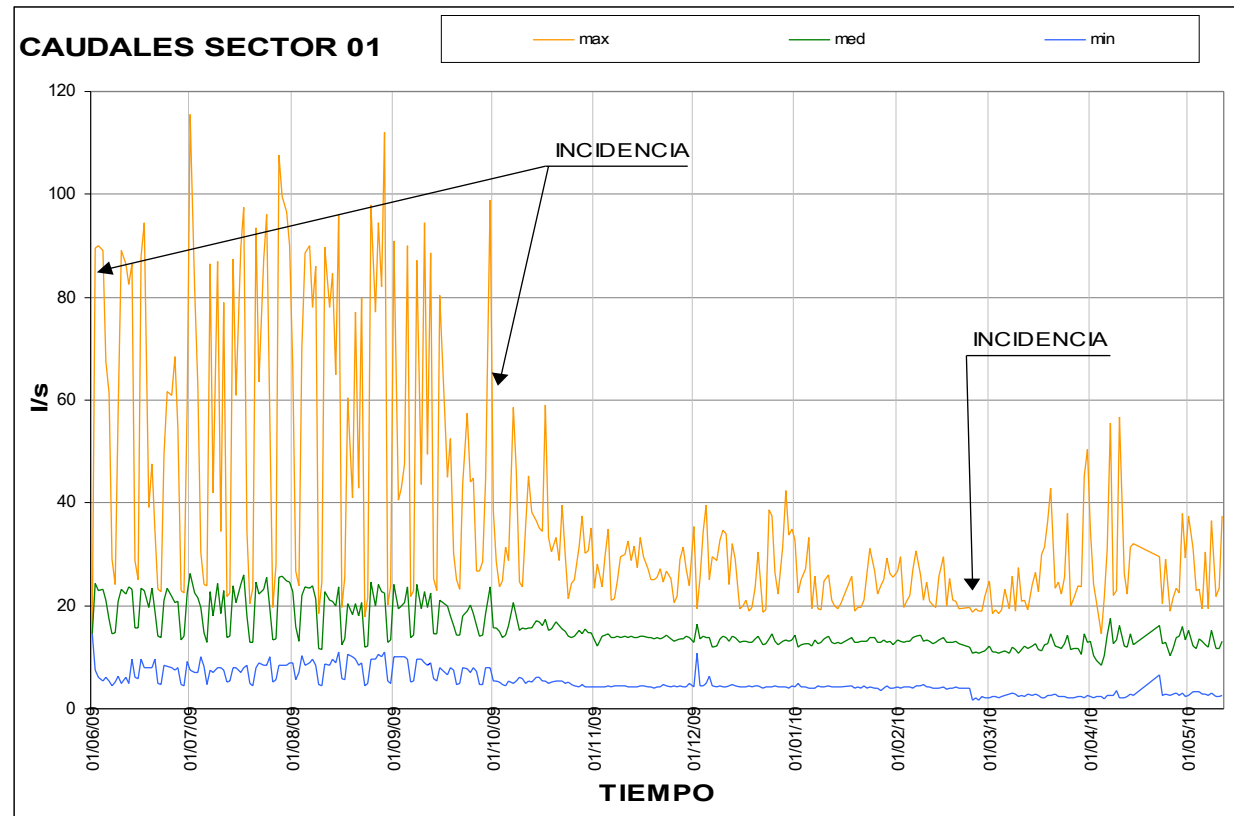

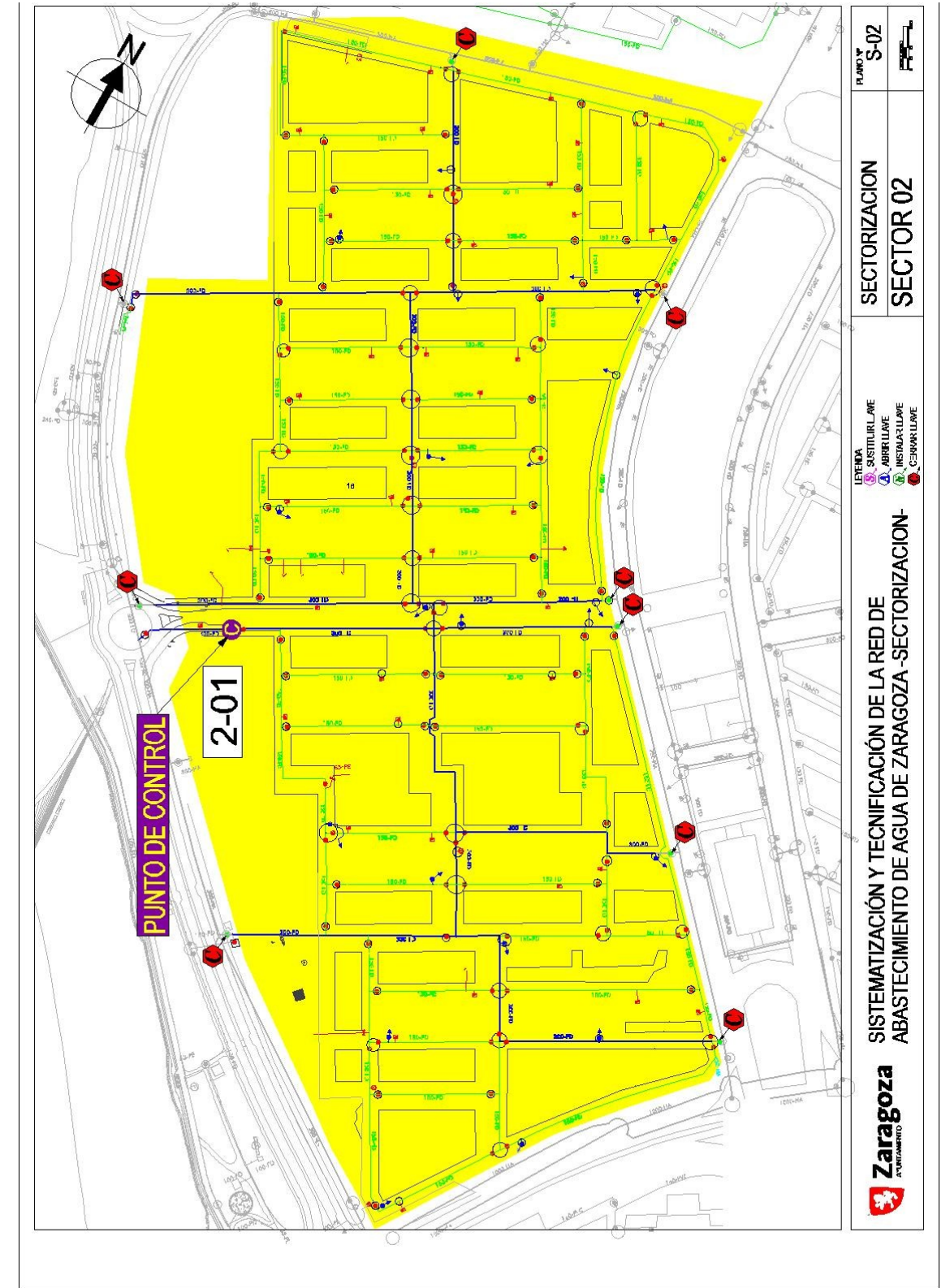
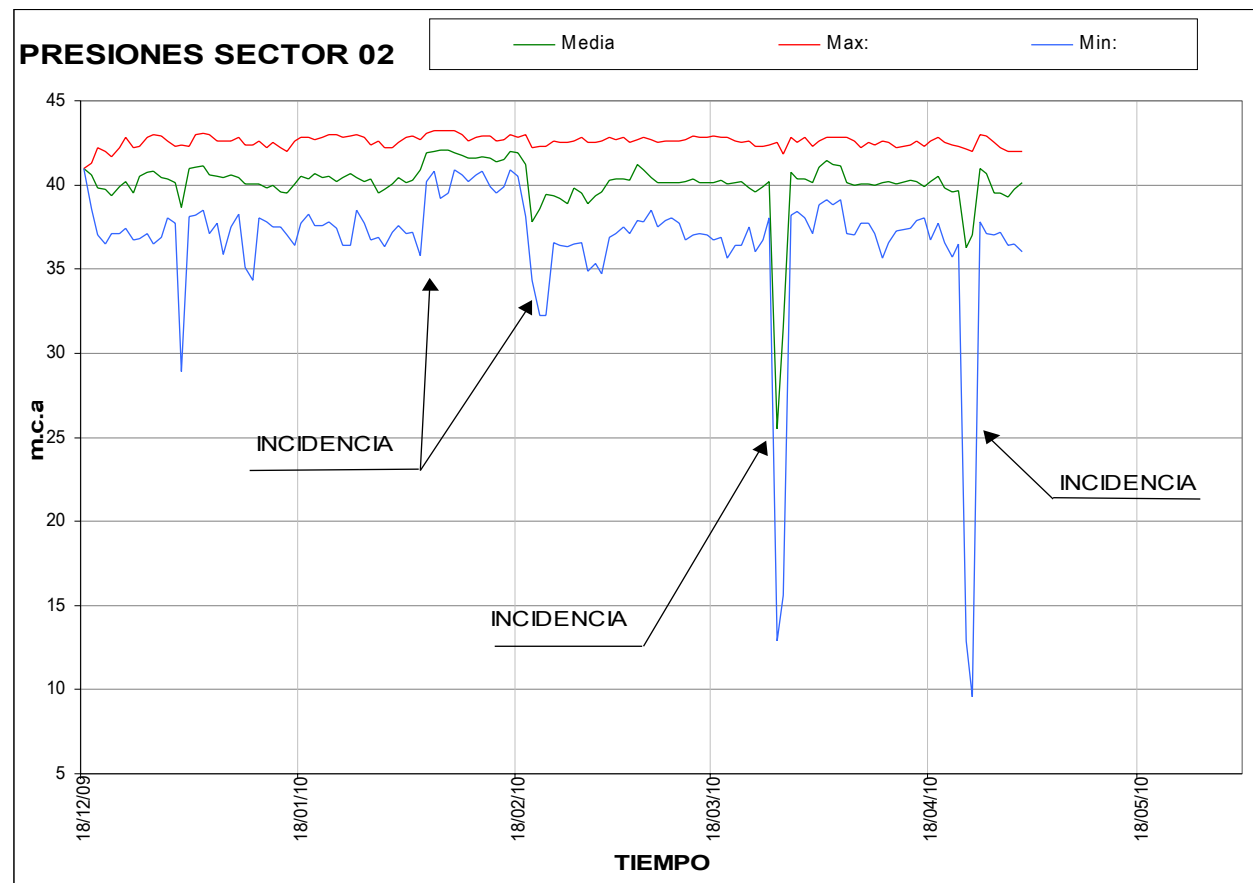
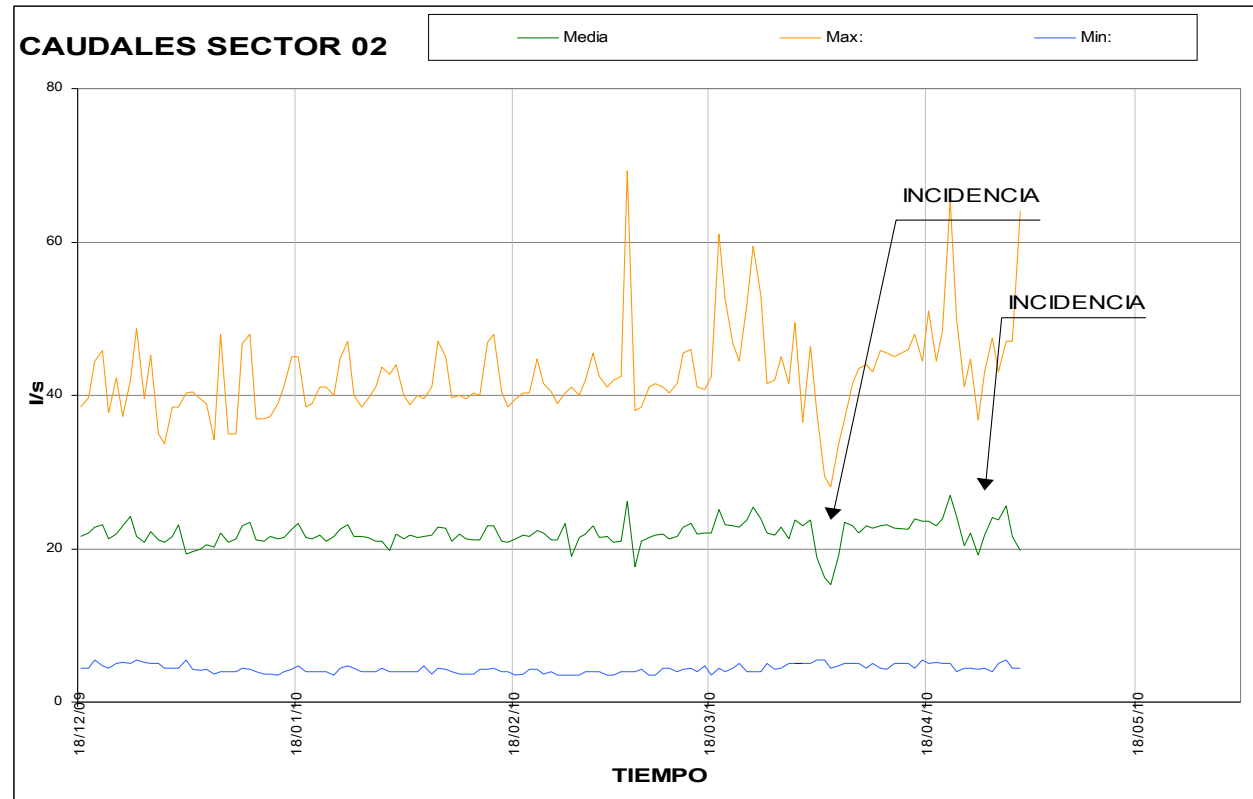

SECTOR 04

The main characteristics of this sector are reflected on the maps and the information document.

- This sector has a surface of approximately 39.1 hectares and is mainly for residential uses
- It contains approximately 8,675 metres of pipeline.
- The estimated averaged consumption in the previous simulation was 31.08 l/s and the average volume of flow measured from 20/02/10 to 1/06/10 was 20.71 l/s
- The average daily minimum volume of flow during the same period was 4.54 l/s.
- The diameter of the flow meter is 300 mm.
- A pressure valve –being adjusted right now- has been put in this sector, limiting pressure only at night (00:30 to 05:45 h) to 30 mWC.

COMMENTS

We can observe the following characteristics from the data obtained from 2/02/10 to 1/06/10, once erased those data out of trend due to problems in the meters (lack of communication, precise errors in the sensors), bursts on the system and handling of the valves that closed the sector.

1. A very low speed in the sensor which can originate unacceptable inaccuracies in the flow meter.
2. The estimated consumption in the simulation is considerably higher than the quantity measured. This aspect must be corrected in the simulation programme.
3. The graphic on the volumes of flows in the sector for the given period are, in principle, in agreement with the logic behaviour of the sector, with an average of 4.54 l/s of daily minimum volume of flow (0.22 times the average volume of flow).
4. From the graphics of the daily averages of volumes of flow and pressure, we can observe the effects that took place in the nearby system (cuts, bursts, etc), that must be taken into account for the interpretation of those data.

Zaragoza		AREA DE INFRAESTRUCTURAS Y PARTICIPACION CIUDADANA		Sección de Cartografía y Explotación de Redes		
E EXPLOTACIÓN DE REDES Y CARTOGRAFÍA						
		FECHA	02/06/10	DATOS DE SIMULACION		
		SECTOR	4	PRESIONES EN PUNTO DE ALIMENTACION		
		AREA (Ha)	39.1	P. Mínima	m.c.a	
		CONSUMO MEDIO l/s *	31.08	P. Media	N/D	
		* (1 semana, lunes-domingo)		P. Máxima	N/D	
ACCIONES PARA LA SECTORIZACION			NUDO DE ALIMENTACION			
CODIGO	ACCION	PRIORIDAD A = alta M = media B = baja	Fecha de ejecución	HORA	ALTURA PIEZOMETRICA	PRESION (m.c.a.)
4 01	Regular la señal del canal 02 (Caudal)	A		0,00		
4 02	conectar los datos al servidor para incluirlos en el SCADA	M	PENDE.	1,00		
4				2,00		
4				3,00		
4				4,00		
4				5,00		
4				6,00		
4				7,00		
4				8,00		
4				9,00		
4				10,00		
4				11,00		
4				12,00		
4				13,00		
4				14,00		
4				15,00		
4				16,00		
4				17,00		
4				18,00		
4				19,00		
4				20,00		
4				21,00		
4				22,00		
4				23,00		
CAUDALIMETRO MODELO ABB MAGMASTER Ø200 + VALVULA REDUCTORA Ø300 + PEGASUS UBICACIÓN C/ Adolfo Aznar FECHA DE PUESTA EN MARCHA EN FUNCIONAMIENTO TELEFONO						
NOTAS NO DA SEÑAL DE RECEPCIÓN DE DATOS, ANTENA VANDALIZADA						
			SECTOR DE PRESIÓN ANTES CASABLANCA DESPUES CASABLANCA			
ANEXO 4: SECTORES ESTUDIADOS						

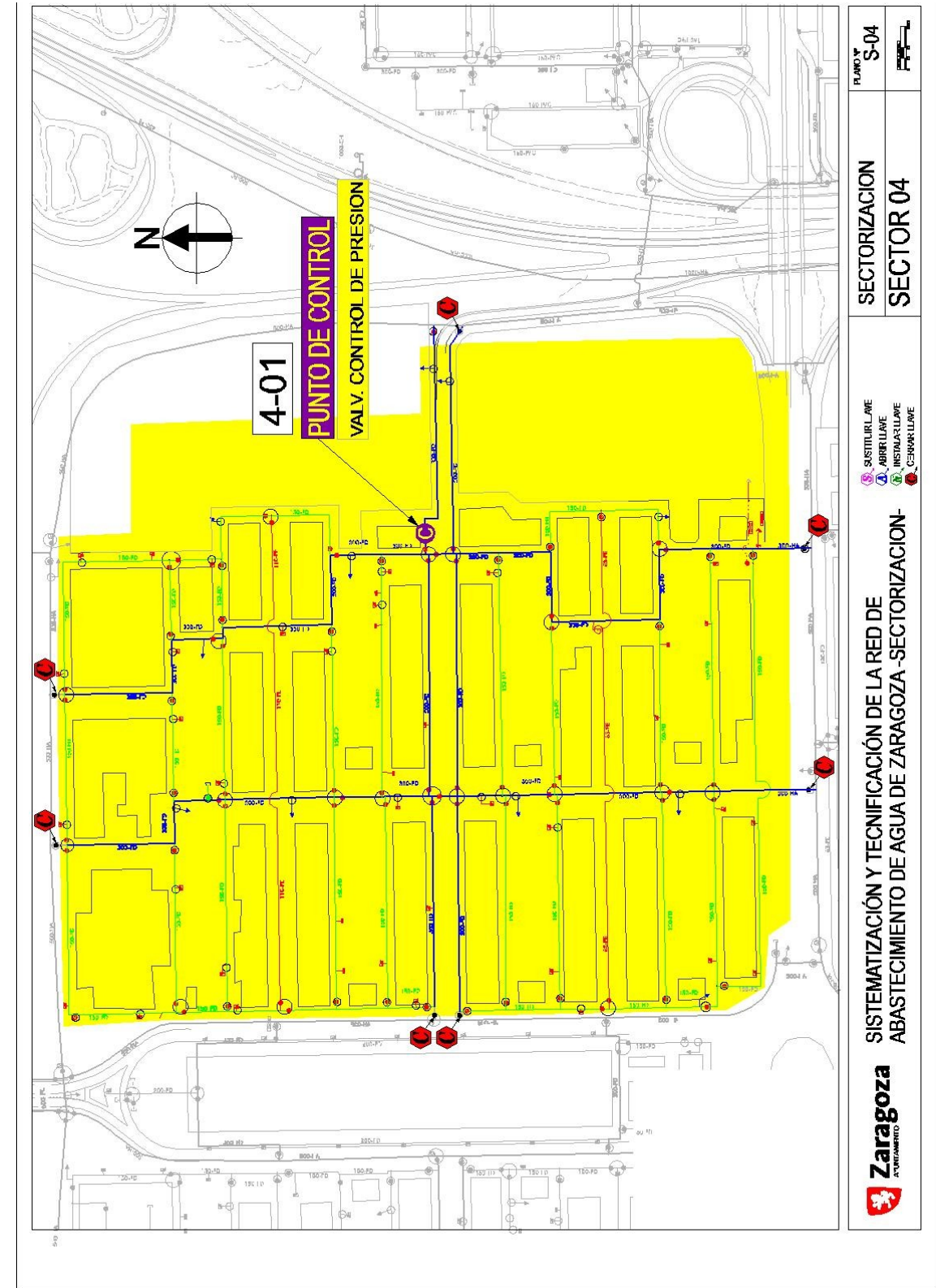
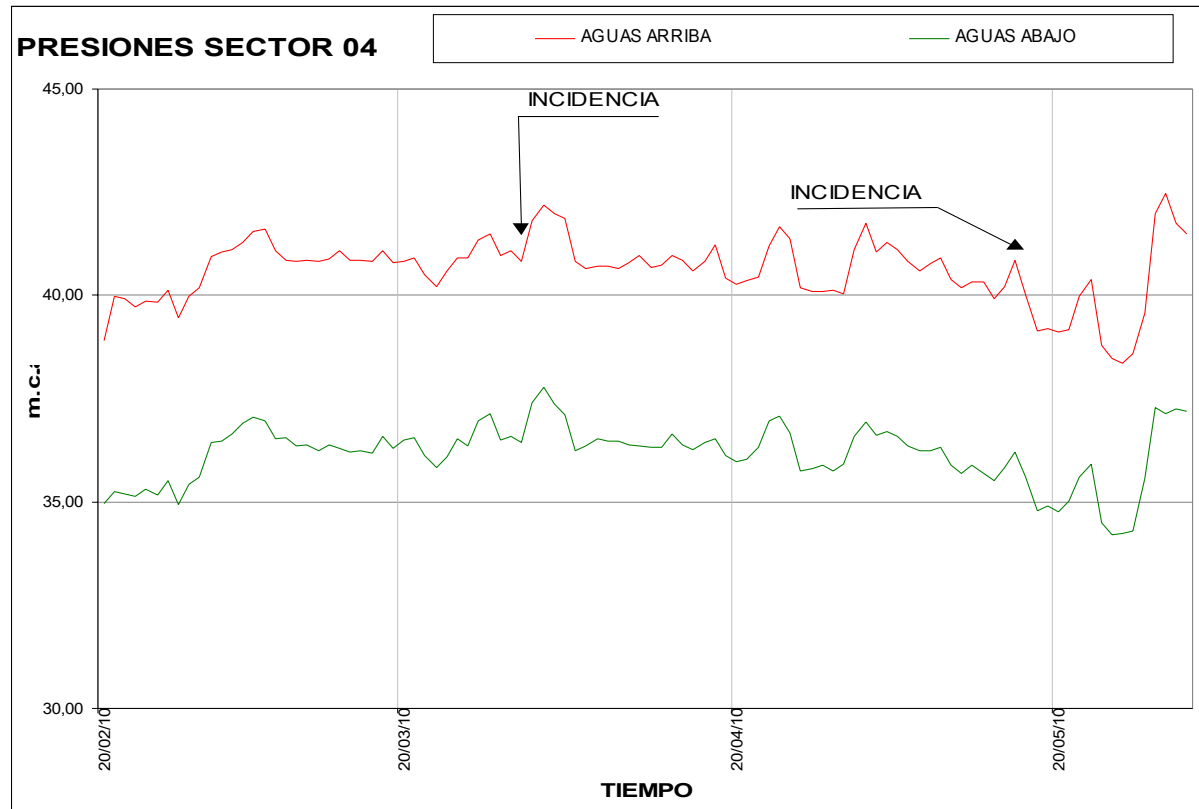
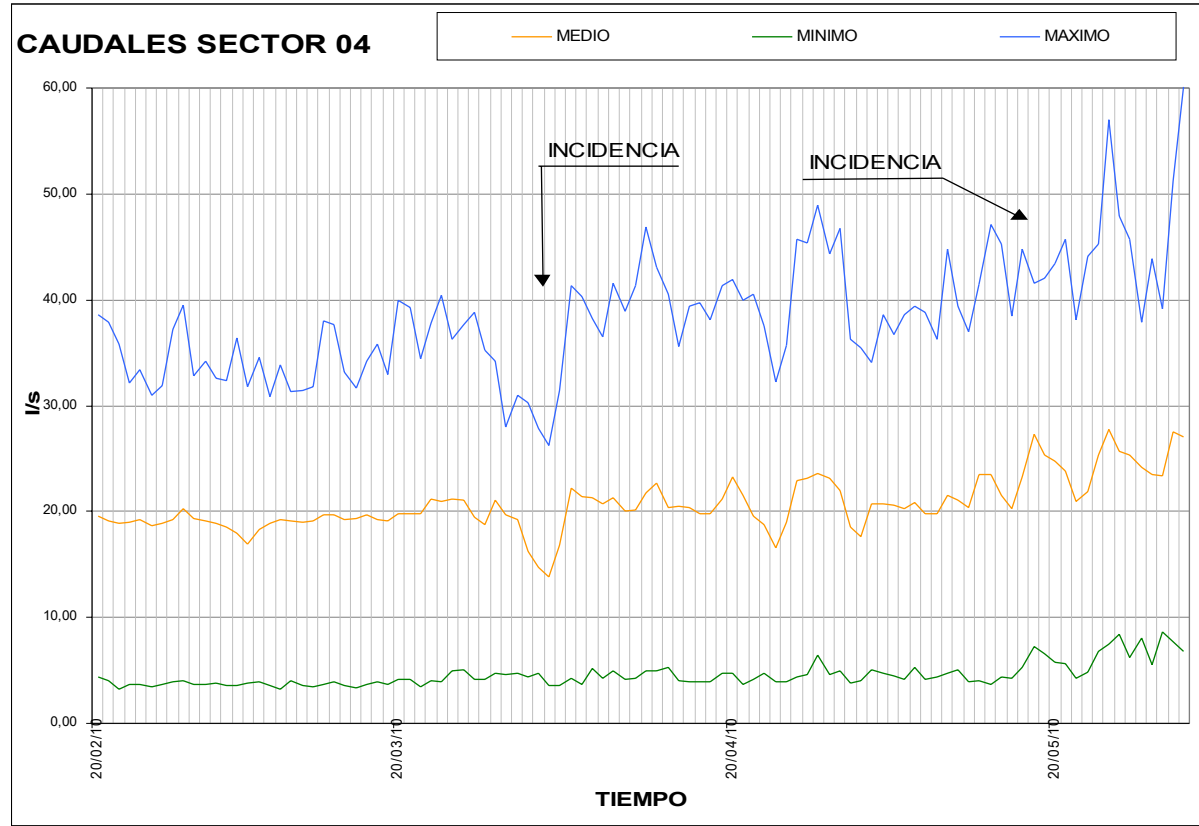

5. The weekly graphic reflects, on the one hand, the pressure up the river of the control valve and, on the other, the pressure piloted down the river by the valve.

At present, the pressure control in this sector is in the assessment period, and, initially, a target pressure of the valve down the river of 25 mWC at night (from 00:30 to 5:45 h), has been fixed.

It has been observed also a lost of stability in the objective limit, with a slight increase of pressure stabilized in a period of 6 months, being now of approximately 30 mWC. This indicates that it is essential to carry out a maintenance process in order to implement a periodical recalibration of the control valve (at least once a year).

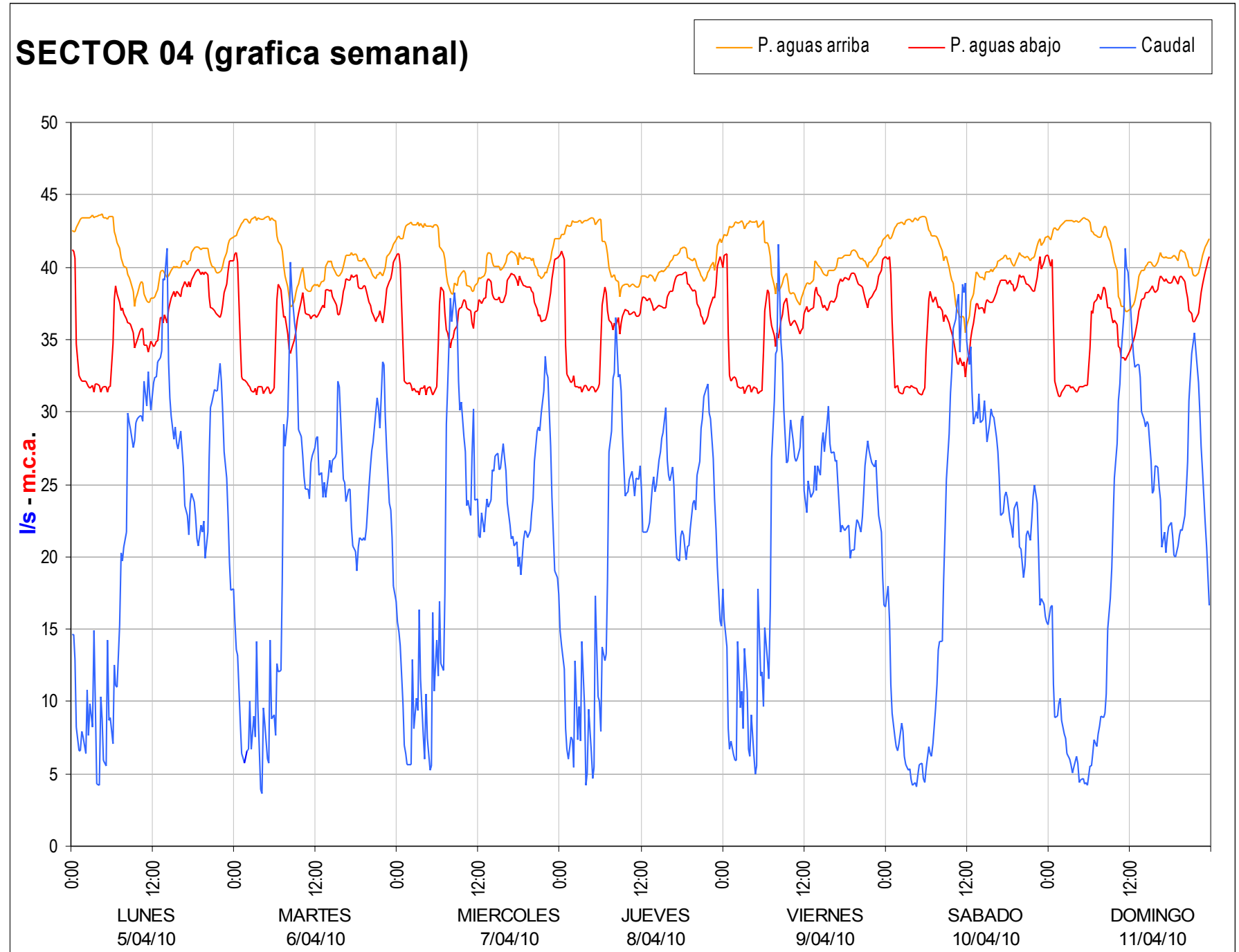

SECTOR 05

The main characteristics of this sector are reflected on the maps and the information document.

- This sector has a surface of approximately 37.6 hectares and is predominantly for residential use
- It contains approximately 8,870 metres of pipeline.
- The estimated averaged consumption in the previous simulation was 37.3 l/s and the average volume of flow measured from 1/06/09 to 11/05/10 was 20.89 l/s
- The average daily minimum volume of flow during the same period was 4.82 l/s.
- The diameter of the flow meter is 300 mm.
- Average speed is 0.34 m/s and the average minimum speed is 0.08 m/s

COMMENTS

We can observe the following characteristics from the data analyzed from 18/12/10 to 1/05/10, once erased those data out of trend due to problems in the meters (lack of communication, punctual errors of the sensors), bursts on the system and handling of the valves that closed the sector.

1. -A very low speed in the sensor which can originate unacceptable inaccuracies in the flow meter.
2. -The estimated consumption in the simulation is considerably higher than the quantity measured. This aspect must be corrected in the simulation programme.
3. -The graphic on the volumes of flows in the sector for the given period is, in principle, in agreement with the logic behaviour of the sector, with a daily minimum average flow of 4.82 l/s (0.23 times the average volume of flow).
4. -From the graphics of the volumes of flow during that period we can observe two different periods: a first one with values from dispersed flows (until 07/07/09), especially on the highest figures. The oscillation between the highest and lowest volumes of flow goes from 98.89 to 4.45 l/s. This was a period of readjustments in the parametrization of the electronic devices and problems with signal picking. In a medium or long period of time, the values obtained must be rejected during the monitorization and processing of the data of the given sector. The values obtained during the second period are more in agreement with the logical behaviour of the sector. It has been obtained an average daily minimum volume of flow of 4.73 l/s (0.23 times higher than the average of 20.54 l/s). This behaviour has been similar to that of sector S-01.

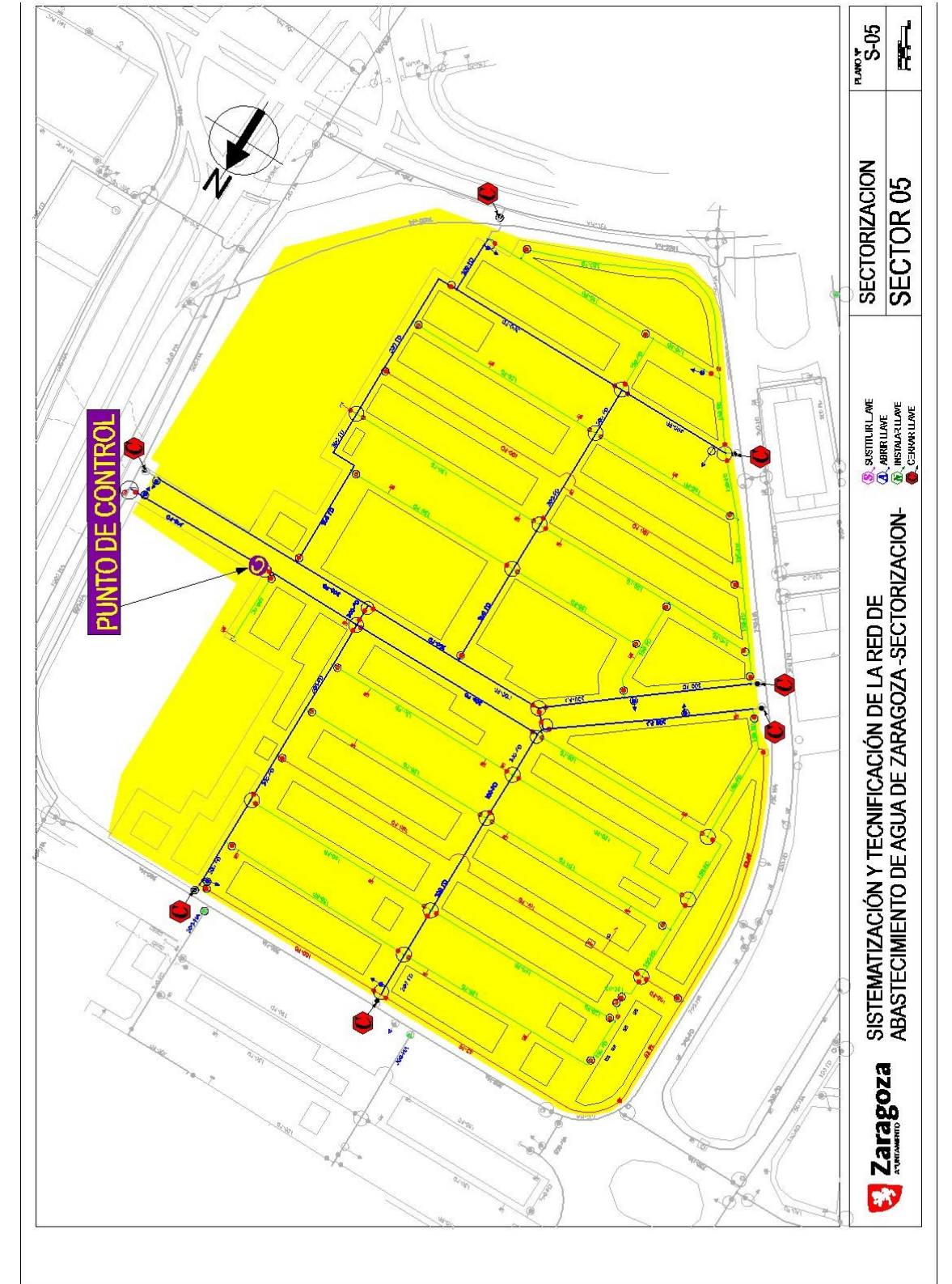
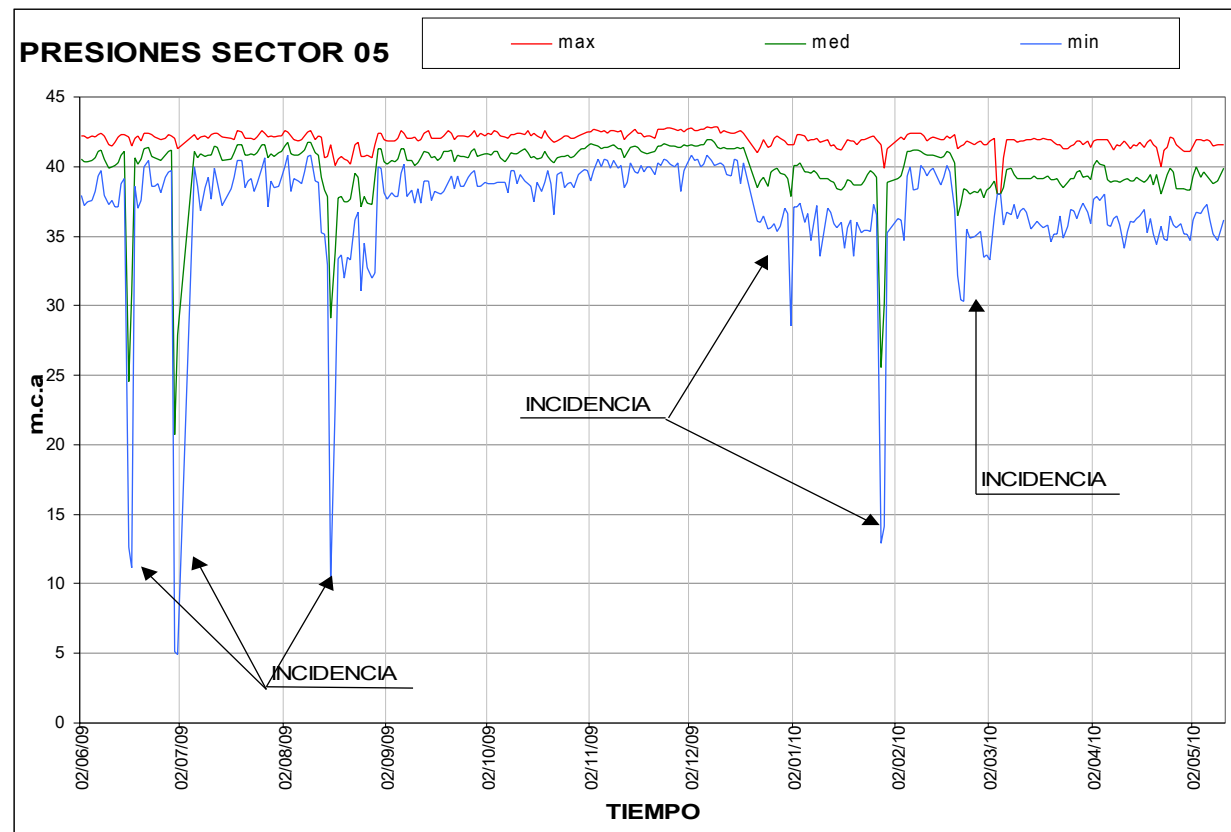
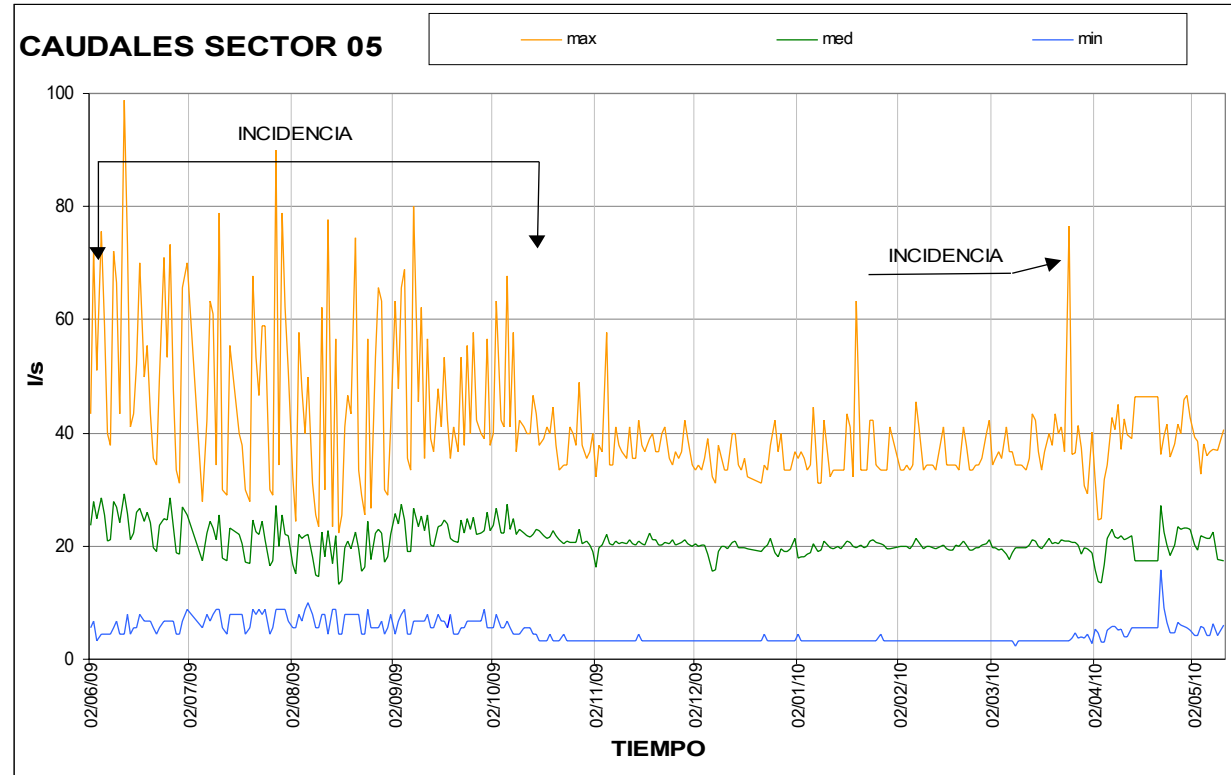

ADVICES AND GOOD PRACTICES

Taking into account the experience obtained from the four pilot sectors, we have arrived at different conclusions on the basic characteristics of the control point: location, parametrization, working procedures, adaptation to the characteristics of the system, and availability and organization of the services of the city of Zaragoza.

Part of these conclusions could be spread and useful for other cities which are analyzing sectorization as a tool for the monitorization, control and improvement in the performance of its water supply system.

A.- PROCESS FOR THE SECTORIZATION OF THE SYSTEM

This section includes a previous survey on precise actions necessary for adapting sectorization to the system. The survey does not pretend to be exhaustive or exclusive since, before determining the action to be implemented, it is necessary a more detailed survey sector by sector, including research "in situ" on the elements of the system, in order to determine in every case, the state of the shut-off valves needed to isolate every sector.

The process for the launching of sectorization includes a protocol with the following concepts:

INITIAL SURVEY

1. Determine the areas that can be sectorized, taking into account the topology of the present system, the materials and its conservation state, and the characteristics of the pressure steps served by the different tanks and pumping stations.
2. A detailed survey of every sector, including information on the valves for isolating the rest of the system and the supply point foreseen, as well as the alternative connection in case it is needed.
3. Initial determination of the necessary adaptations for the existing system and the correct running of the area, trying to avoid the "fondos de saco" that could produce an excessive retention of water in the system.
4. Simulation of present and future pressure conditions, checking the existence of minimum parameters of quality for the supply service in every sector. Possible modification of the initial layout and supply system for the target sector.

5. Foreseen actions in every sector referred to need to install new llaves de corte, replacing those valves in bad state (thanks to the information provided by the Department of Guardallaves).
6. Foreseen replacement, reorganization or installation of stretches for the correct running of the system.
7. Foreseen the manipulation of valves (opening, closing, etc) needed for running the sector.
8. Working out of the graphic and written information included in the previous report:
 - Map of the floor plan of the sector with basic instruction on its layout, manipulation of the valves, and actions for a precise adaptation.
 - Maps of the results of the simulations: present and future highest and lowest pressure
 - Document with data of the area: surface, estimation of the average volume of flow, main actions for adaptation (not exhaustive), data on the control point (type of flow meter, telephone number, position, etc).
 - Initial estimation of data for the simulation.



IMPLEMENTATION

1. Checking “in situ” of the state of the system and the valves, control of opening and closing, pressure check, leaks, etc
2. Determine the valves to replace.
3. Establishment of the control point: civil works, plumbing, electric system.
4. Implementation of actions for adaptation (“top” priority actions are compulsory), replacement of valves, new llaves de corte, stretches of pipeline, etc.
5. Controlled manipulation of the valves for implementing the sectorization.
6. Control and monitoring of possible dysfunctions: supply errors, uncounted losses of pressure, etc.
7. Integration of the data supplied by SCADA

MAINTENANCE

1. Control and monitorization of the information received and integrated in SCADA
2. Maintenance of the control points (periodical inspection, resolution of problems, etc)
3. Use of the data received for controlling unregistered consumptions, detection of dysfunctions, leaks, etc, as well as its integration in the simulation devices of the system.
4. Process of continuous updating and improvement of access to data, control of consumption, system planning, etc.

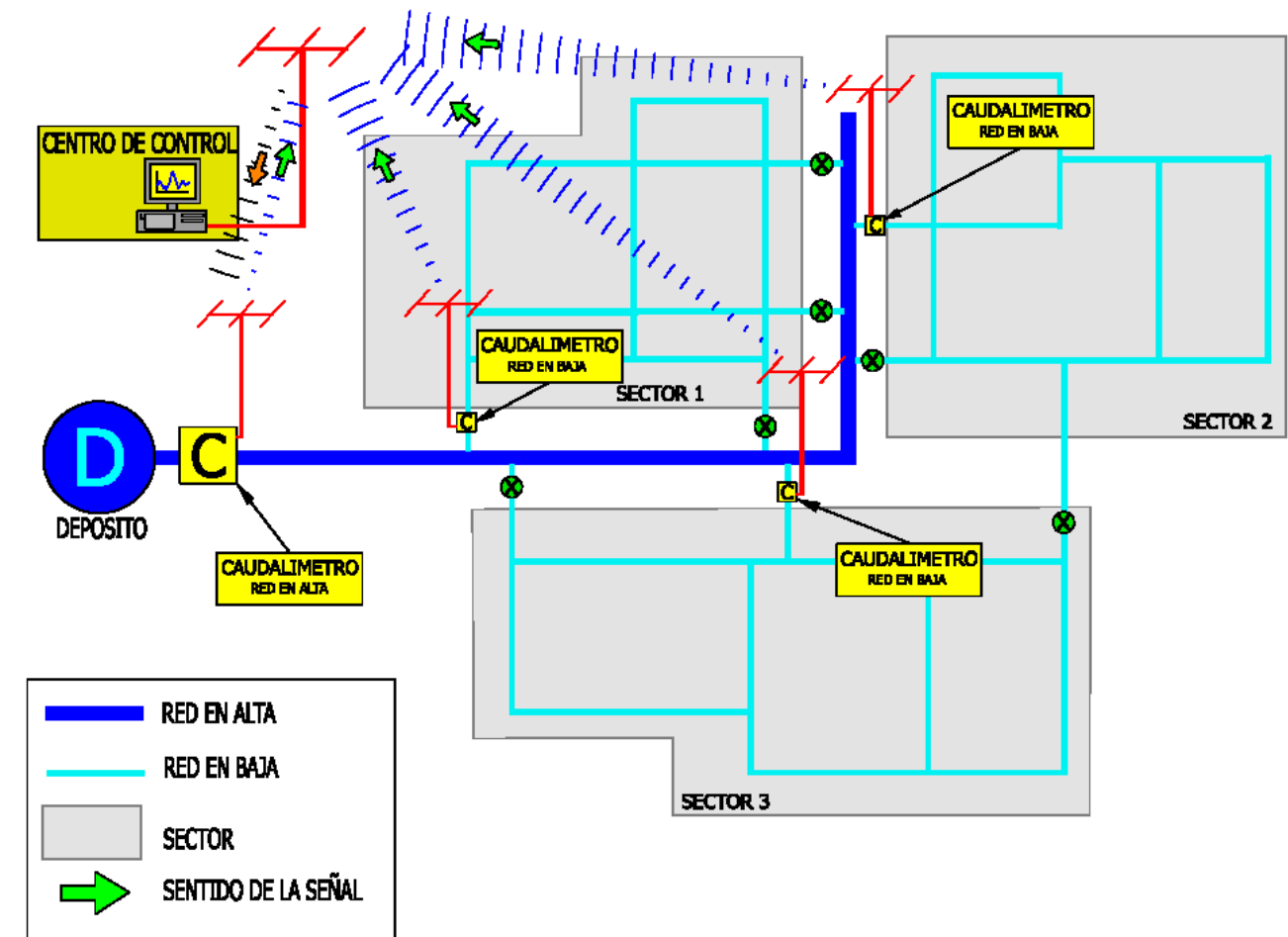

ESQUEMA DEL SISTEMA DE SECTORIZACION

B.- PARAMETERS USED FOR SECTORIZATION

These advices are to be taken into account in the projects for the installation and/or renovation of the supply systems of the city of Zaragoza, in case they affect to the location of a control point foreseen for the sectorization of the system.

SECTORIZATION

The sectorization of the supply system implies the creation of two systems, one en alta composed of big diameter pipes (with 300 mm or more), and another one for distribution, with smaller diameters (at least 300 mm).

Every sector must have a minimum of two connections with the red en alta, through a short stretch of pipe of, at least, 300 mm of diameter. A flow meter will be put in one of these stretches, and, all of them, will have a shut-off valve to isolate a specific sector with the red de alta.

The following criteria will be taken into account for the definition of the sector:

1. Topology of the distribution system
2. Equivalent number of inhabitants: around 12,000
3. Consumption by person and day: =>250 l/person day
4. Peak factor: 2.5 times the average consumption
5. Minimum factor of consumption: 0.20 times the average consumption
6. If possible, the sector will have a 300 mm diameter pipeline all around it
7. A simulation will be performed in every section in order to know the suficiencia de partida of the connection for supplying the section.

CONTROL POINT

COMPONENTS OF THE SYSTEM

The system proposed for flow measuring includes an electromagnetic flow meter to measure the main parameters of water flow such as flow itself, speed, direction, accumulated volume, etc. Nevertheless, we will only use the average flow every 15 minutes.

The above mentioned data are transmitted to the datalogger which sends the data to the central unit once a day through SMS.

The system also includes a manometric intake placed in the pipe that sends the signal to the register.

The flow meter must have a battery for at least 5 years and a data logger GSM/SMS with battery also for 5 years and able to store the average consumption and pressure every 15 minutes. Once a day, the data logger will sent those data to the control center through a SMS message.

INSTALLATION

The flow meter must be planned for a minimum speed of 0.25 m/sec in order to be within the correct parameters for flow measuring, provided that the lost of flow due to the reduction of diameter can be assumed by the system.

In principle, it has been enough to place flow meters of \varnothing 200 mm for the majority of the sectors foreseen for Zaragoza system.

The flow meter must be put between two shut-off valves placed at an adequate distance to make possible repairs or replacements without shutting-off an excessive stretch of pipe, and, in any case, without cometidas or in-take points in that stretch. During the cut of flow, the valves of an alternative connection point of the sector will be opened to avoid an unnecessary lack of supply to the consumptions points.

It is recommended to install shut-off valves out of the meter flow small box in order to avoid displacements of the pieces of the pipes when pieces are manipulated due to pressure and a very limited securing.

While assembling the meter flow, there must be at least a certain distance between the pieces that can produce a considerable disruption in water flows (bends, ts, valves, etc). Those flows must be 5 times the diameter of the flow meter in the direction of the source of the water flow, and three times the diameter in the opposite direction.

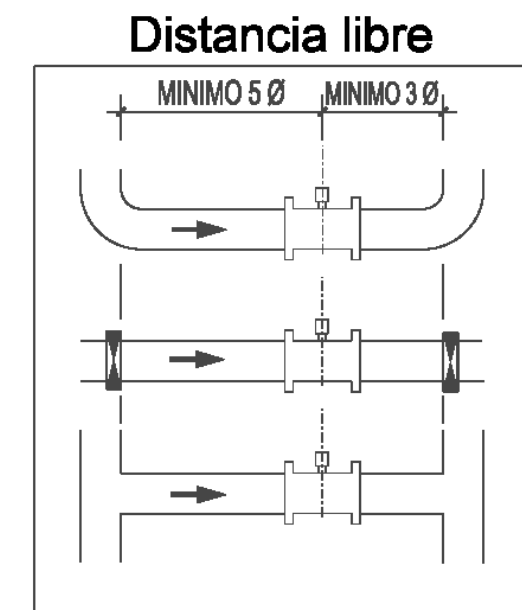

TYPICAL ASSEMBLY -

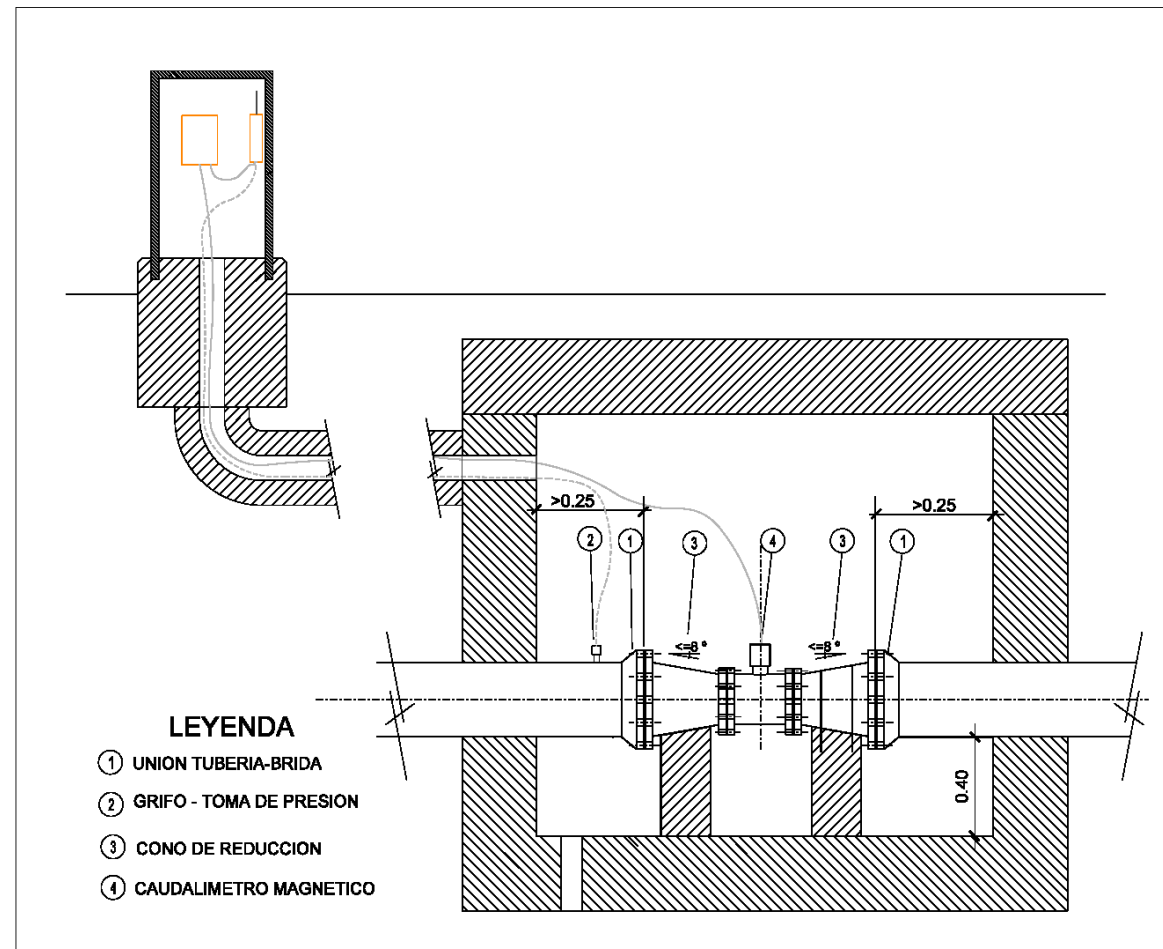

In the majority of cases and to avoid an excess of turbulences, the flow meter will be placed between two adapters with a groove angle of 8° or less. A tapping point must be placed at the pipe.

As an example, in pipes with a diameter of 300 mm, the diameter of the meter flow will be 200 mm and will be placed between adapters with 300/200, all of them placed inside a small box of 1.50 x 2.00 m. (graphic 2)

The electronic devices and the recorder will be placed in a different point of the small box, with the meter.

It is better to place those devices (if the situation allows it), inside a lifted closet with similar dimensions to those indicated in graphic 3, or inside a closed non-metallic lid small box, with adequate internal dimensions for the installation, inner drain and placing of the electronic devices, and at least 15 cm from the floor of the small box.

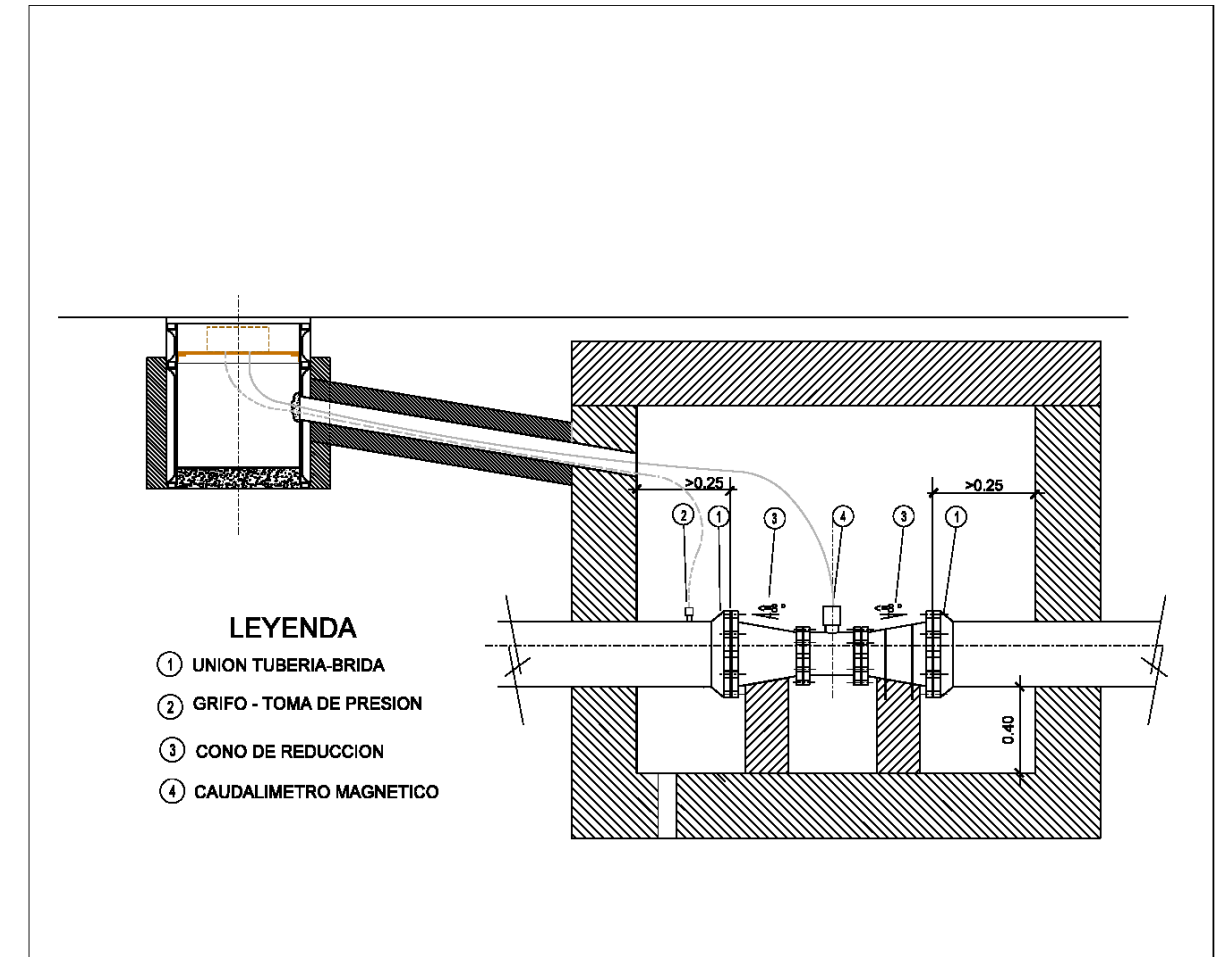

TASKS TO CARRY OUT

The specific tasks that, apart from the usual ones –demolition, excavation, filling-up, main small box made of reinforced concrete, carrete de desmontaje adapters, “ts”, intake tap, replacement of pavement, etc- will be these:

Measurement unit:

A digital electromagnetic flow meter (with X mm of diameter), with battery for 6 years and independent electronic devices, even with data recorder type GSM/SMS or similar, with battery for five years and capacity of storage every 15 minutes, as well as average pressure. Data are sent every 24 hours to the control center by SMS, including and earth system ring, pressure system in the pipe, flexible pressure pipe for connection to the data recorder, and accessories. The device is totally installed, parametrized, tested and working.

Closet for electronic devices -

A prefabricated reinforced concrete closet with these characteristics: absorption <10%, strength against pushing-up <4N/mm², breaking load <7KN. External measures 84x49x26 cm and internal useful measures 81x46x20 cm, 35x45cm door made in white lacquered aluminium with bolt lock and padlock. The weight of every unit is 64 kg. The closet is on a concrete base HM-12.5 of 59x60x36 cm. Tasks include a piping of PE of Ø110 mm wrapped up in a concrete prism HM-12.5 of 30x309 cm to the small box where the flow meter is placed, including also fully built secondary tasks.

Small box for electronic devices

Each unit has internal minimum dimensions of 58x58x60 cm, made in polypropylene reinforced with a 20 % of fibreglass, concrete block HM-12.5 with external measures of 88x88x75, works of earth and stonework, and holes for pipes, totally finished. It is included PE piping of 11 mm of diameter wrapped up in a concrete prism HM-12.5, of 30x30 to the small box where the flow meter is placed, event secondary works, and fully built.

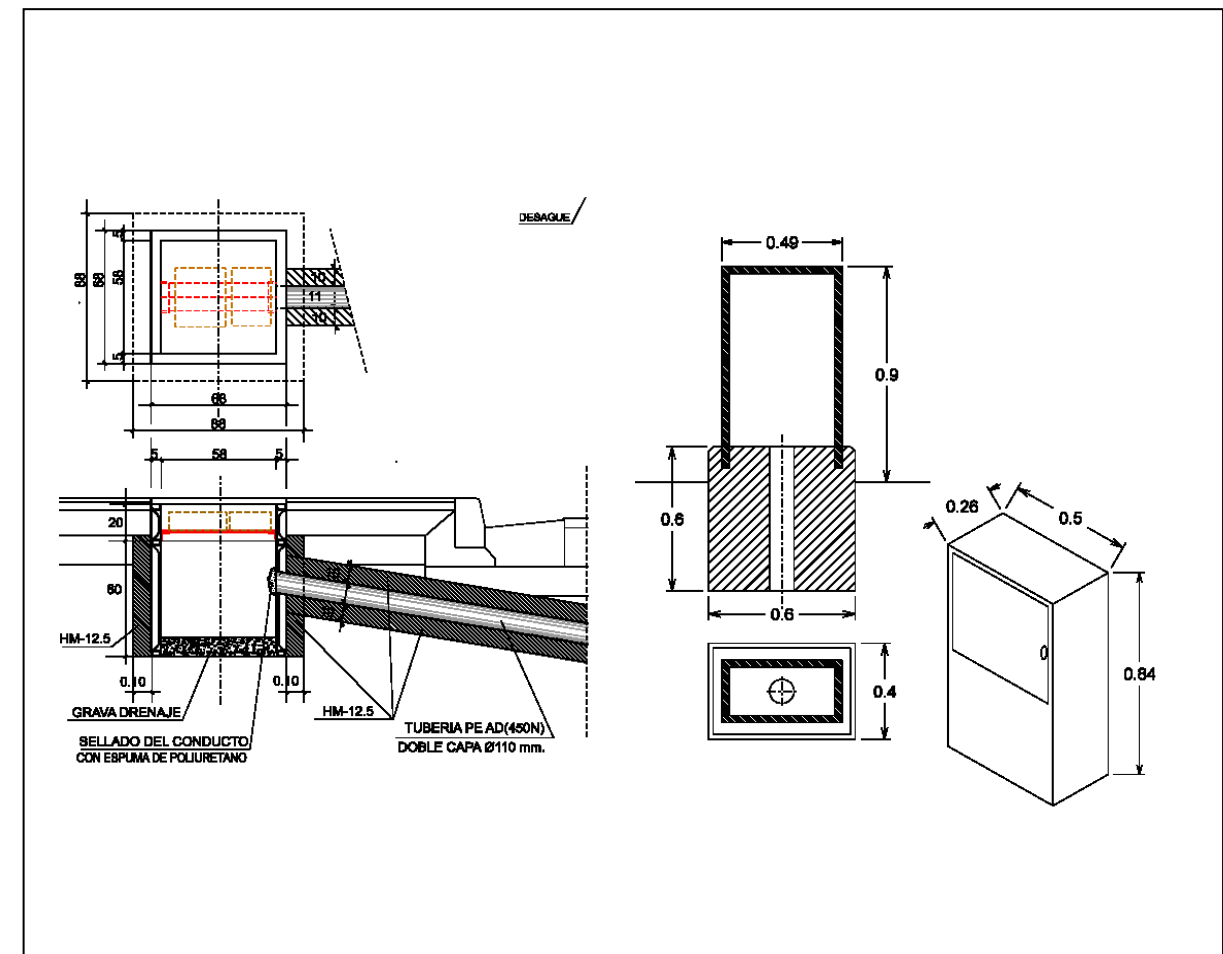

MODELOS -

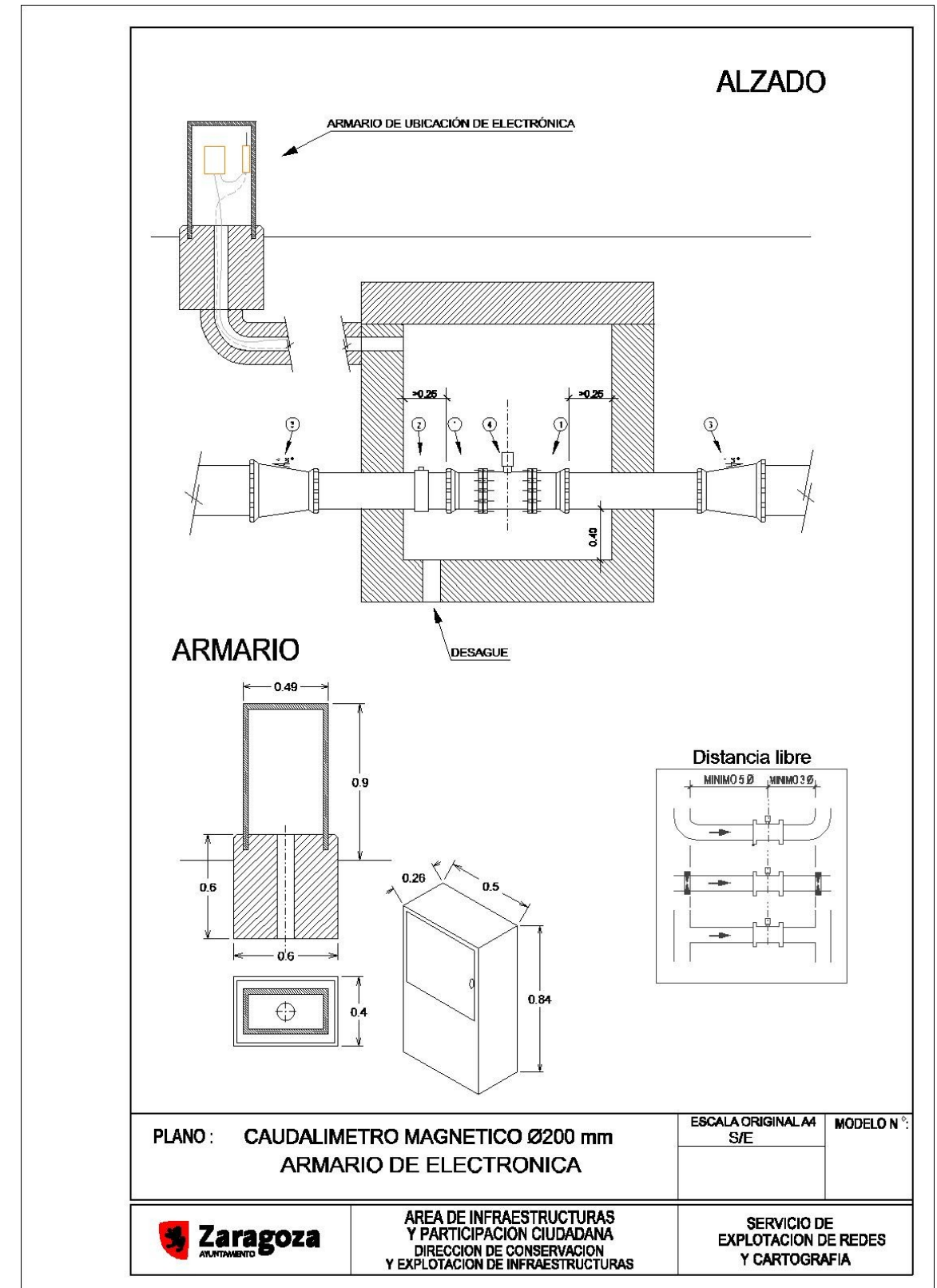
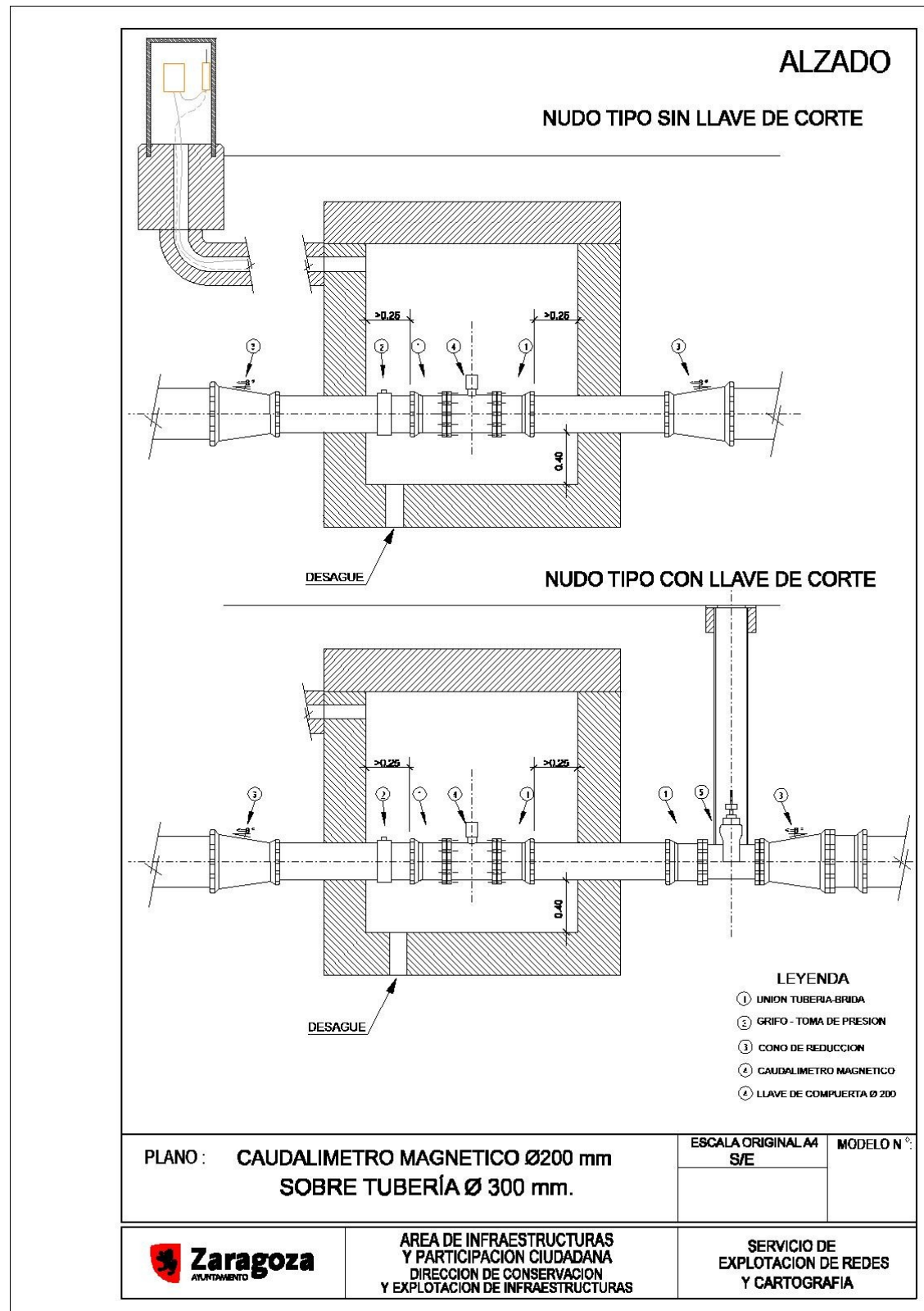

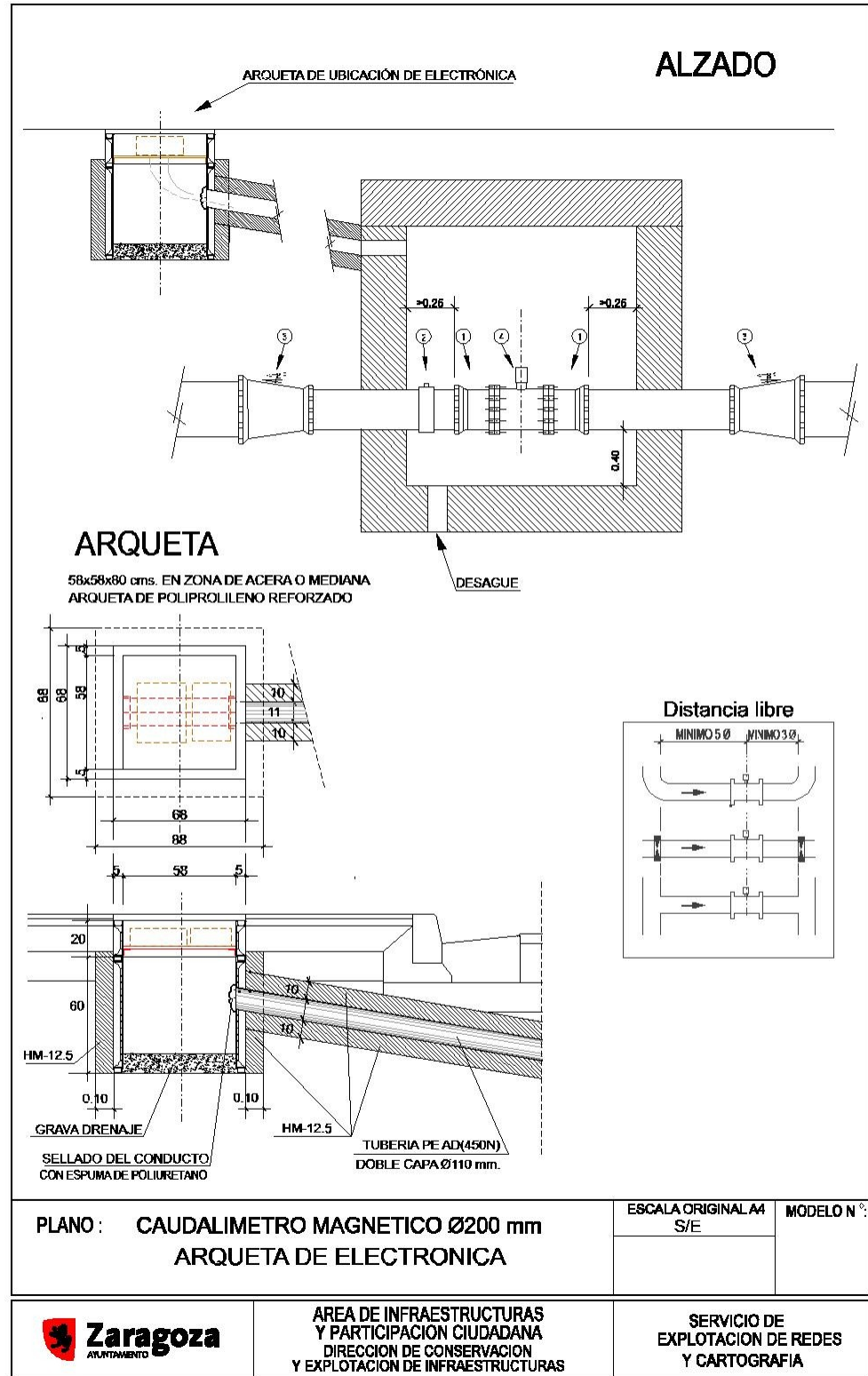

C – FINAL ADVICES

After the experience obtained in the four pilot sectors, several advices to continue with the sectorization of Zaragoza system have been defined.

1. Include the highest degree of standardization in the control points.

The adoption of constant starting parameters for planning the sector, give us as a result several similar characteristics in every control point. The standardization of the points (morphology of the civil works, plumbing, electronic devices, etc) will produce a saving in planning time, the implementation of the control points, and the periodical maintenance of the system.

2. Previous evaluation of signal coverage in case a wireless system (telephone, radio, etc) is used to spread data.

There have been problems with the spreading of signals in several control points of the pilot experiences. Therefore, it has been necessary to modify the characteristics and place of the aerials.

3. Reduce the diameter of the flow meter with respect to the supplying pipe, assessing during the simulation the commitment speed-lost of charge, in order to maintain the speed of flow within the acceptable limits of accuracy of the meters.

In relation to this, it has been gauged a persistence of a low speed pass by the parameters and size of the sectors analyzed. A flow meter of 200 mm Ø and a supply pipe of 300 mm for the above mentioned parameters as well as supply pipe of 300 mm have been proposed for the standardized control module.

4. Keep the electronic devices in closets or small boxes easily accessible for the maintenance and parametrization "in situ".

Since some accesses to the control points can be found in roads, which makes more difficult a safe access, it is advisable to put the electronic devices (flow meter and datalogger) into small closets or small boxes placed on the pavement. This will allow us have access in good conditions of comfort and security. Nevertheless, the closets or small boxed must have a lock to avoid thefts and vandalism.

5. In case there is not power supply for the equipment, it is advisable to use the SMS system, which have batteries with a longest duration, -by limiting the equipment to sending only the data taken and stored in the data logger every 24 hours.

This implies the need of limiting the bidirectional communication equipment-control center to a limited period of time (communication window), generally an hour a day for the remote configuration or for asking specific data by GSM for a bigger power consumption.

6. It is advisable to install the nearby shut-off valves out of the closet where the flow meter is.

In some cases, a perfect securing of the valves will not be possible due to the characteristics of the connection pieces (bridas, plugs, etc) of the pipes and special pieces (such as adapters, shut-off valves, etc.).

Sometimes, after closing the valves nearby the flow meter for its possible replacement, water pressure can produce the displacement of pieces that can produce an an accident.

City of Zaragoza, 4 June 2010

Esteban-Raúl Bello Pérez
Head of the Section of Cartography
and Exploitation of Systems

Alfonso Narvaiza Marqués
Head of the Service of Exploitation
of Systems and Cartography